



Universität Potsdam

Michael Frese, Harry Garst, Doris Fay

Making Things Happen: Reciprocal Relationships between Work Characteristics and Personal Initiative (PI) in a Four-Wave Longitudinal Structural Equation Model

first published in:

Journal of Applied Psychology. - 92 (2007), 4, pp. 1084 – 1102
ISSN 0021-9010

Postprint published at the institutional repository of Potsdam University:
In: Postprints der Universität Potsdam : Humanwissenschaftliche Reihe ; 28
<http://opus.kobv.de/ubp/volltexte/2008/1827/>
<http://nbn-resolving.de/urn:nbn:de:kobv:517-opus-18278>

Postprints der Universität Potsdam
Humanwissenschaftliche Reihe ; 28

Making Things Happen: Reciprocal Relationships between Work Characteristics and Personal Initiative (PI) in a Four-Wave Longitudinal Structural Equation Model

Michael Frese¹⁾, Harry Garst²⁾, and Doris Fay¹⁾³⁾

1) University of Giessen, Germany

2) University of Amsterdam, Roetersstraat, Amsterdam, The Netherlands

3) Aston Business School, Aston University, Birmingham, England.

Frese, M., Garst, H., & Fay, D. (2007). Making things happen: Reciprocal relationships between work characteristics and personal initiative in a four-wave longitudinal structural equation model. *Journal of Applied Psychology*, 92(4), 1084-1102.

Acknowledgment: Other members of the project team have been Sabine Hilligloh, Thomas Wagner, Jeannette Zempel, Christa Speier. The project was supported by the Deutsche Forschungsgemeinschaft (DFG, No Fr 638/6-5) and the programmagroep work and organizational psychology, University of Amsterdam. For very helpful criticism, we thank Katherine Klein (who helped at several crucial stages of writing this article), Frank Landy, David Hofmann, Elizabeth Morrison, Andreas Utsch, and Dieter Zapf. Correspondence concerning this article should be addressed to Michael Frese, Department of Psychology, University of Giessen, Otto-Behaghel-Strasse 10F, D-35394, Giessen, Germany. E-mail: michael.frese@psychol.uni-giessen.de

ABSTRACT

We used the frameworks of reciprocal determinism and occupational socialization to study the effects of work characteristics (consisting of control and complexity of work) on personal initiative (PI) -- mediated by control orientation (a second-order factor consisting of control aspiration, perceived opportunity for control, and self-efficacy) and the reciprocal effects of PI on changes in work characteristics. We applied structural equation modeling to a longitudinal study with four measurement waves ($N=268$) in a transitional economy – East Germany. Results confirm the model plus one additional non-hypothesized effect. Work characteristics had a synchronous effect on PI via control orientation (full mediation). There were also effects of control orientation and of PI on later changes of work characteristics: As predicted, PI functions as partial mediator, changing work characteristics in the long term (reciprocal effect); unexpectedly, there was a second reciprocal effect of an additional lagged partial mediation of control orientation on later work characteristics.

Making Things Happen: Reciprocal Relationships between Work Characteristics and Personal Initiative (PI) in a Four-Wave Longitudinal Structural Equation Model

An important question in philosophy and the social sciences has been whether people are determined by their work (Marxism) or whether people can actively shape their environment (cf. A. Schopenhauer's, 1819/1998, "primacy of the will"). We use two concepts – personal initiative and reciprocal determinism – to understand and empirically look at this issue.

A great deal of theory and research within organizational behavior and industrial and organizational psychology suggest that work characteristics influence individual attitudes and behaviors. Within this literature, work characteristics are conceptualized and studied as exogenous variables, determining in turn individuals' adjustment to their work. People's motivation is affected by work characteristics (Hackman & Oldham, 1976), they are socialized by the work characteristics (occupational socialization; Frese, 1982) and by management (organizational socialization; Van Maanen, 1976), and they are trained to do the job tasks (Latham, 1989). Thus, work characteristics are conceptualized to be outside the employees' influence.

Countering this conceptualization is a growing literature examining the active side of people's behaviors at work. For example, Morrison (1993, p. 173) argues that "...socialization is a process affected not only by organizational initiatives, but also by newcomer initiatives." Ashford and Tsui (1991) and Morrison (1993) have studied concepts such as active feedback seeking. Further, Hacker (1973), Ilgen and Hollenbeck (1991), as well as Staw and Boettger (1990) have been concerned with employees' task revisions. In addition, Organ (1988) has developed the concept of organizational citizenship behavior.

We think that this more active conceptualization of employees is beneficial and appropriate, but that it has not gone far enough. Theorists and research have by and large not systematically examined the ways in which employees may actively change their work characteristics (Wrzesniewski & Dutton, 2001). Thus, work characteristics are often conceptualized as extraneous variables, even in the studies and theories highlighted above. For example, active feedback seeking implies that feedback is sought to understand the work characteristics and the organization better but not how to change the work characteristics and the organization.

By further developing the concept of personal initiative, we would like to contribute to understanding how people can actively affect their work characteristics. People show *personal initiative* (PI) when they engage in self-starting and proactive behaviors that overcome barriers on

the way toward a goal (Frese, Kring, Soose, & Zempel, 1996). Given the nature of work in the 21st century, PI is likely to become increasingly important (Frese & Fay, 2001) because (a) companies are moving from stable structures to change oriented organizations (Lawler, 1992); (b) these changes bring new responsibilities to rank and file workers (Wall, Cordery, & Clegg, 2002); (c) people who just react to obvious situational cues or who only follow orders will be unable to actively carry changes forward (Frese & Fay, 2001), and (d) organizations are placing more responsibility on the individual for career management, including training and development (Hall, 1996; London & Mone, 1999). Theoretically, the PI concept is needed to understand how people can change the situation in which they work and how they determine changes in work, in processes, in products, and in society.

Even though we emphasize people's active approaches as drivers of changes, we do not ignore that these active approaches are themselves driven by other factors. *Reciprocal determinism* (Bandura, 1997), which argues that "people are both producers and products of social systems." (p.6), integrates both lines of thought. Despite its theoretical influence, to our knowledge, there exists little systematic or longitudinal examination of this concept in work settings (Vancouver, 1997). Thus, based on a longitudinal field study, we attempt to further develop the concept of reciprocal determinism and to provide a more complete picture of the development of PI as a result of work characteristics. Our design is based on a six-wave longitudinal study in East Germany; four of these waves are used to test our ideas.

Thus, our article attempts to contribute to the literature by testing reciprocal determinism in the field and by introducing PI into this model. To examine alternative models, we tested our hypotheses with data from a longitudinal study with four measurement points. The study on PI was carried out in East Germany because a high amount of change in workplaces occurred there after reunification and this makes it easier to look at reciprocal effects. In the following we introduce the concept of PI and then develop the theoretical model underlying our study in more detail.

CORE CONCEPTS AND THEORETICAL MODEL

Figure 1 displays our theoretical model. We assume that (1) *work characteristics* change *control orientation* and that (2) there is a reciprocal path from *personal initiative* to changes in work characteristics. This implies two mediation effects: Work characteristics should change PI via the mediator control orientation and control orientation leads to changes in work characteristics via the mediator PI. This also means that the process is energized by three "drivers" – the work characteristics, control orientation, and personal initiative (cf. Figure 1).

The Concept of Personal Initiative (PI)

Personal initiative refers to behaviors mainly directed toward work and organizational issues that are characterized by the following aspects (Frese & Fay, 2001): self-starting, proactive, and persistent in overcoming barriers. The opposite of personal initiative is a reactive approach in which one is told what to do, in which the here and now determines the actions (no proactivity), and in which a person gives up when barriers and difficulties arise (Hacker, 1992).

Self-starting implies that the behavior is regulated by goals developed without external pressure, role requirements, instruction, or doing an “obvious” action. Thus, PI is the pursuit of self-set goals in contrast to assigned goals. An example is a blue-collar worker who attempts to fix a broken machine even though this is not part of his or her job description. Frequently, initiative deals with sub-problems of an assigned task or with issues that are not obviously related to the task. Blue-collar workers may perform additional checks on the quality of material or of prior work. For example, in one study, we observed that the task of drilling a hole in an automobile could damage cables located below the drilling surface. In such a case, the worker may think of the danger of drilling too deeply and tell others about it. PI sometimes implies that a person takes charge of an idea that has been around for a while but that has not led to action before. A secretary who buys bottled water for a guest speaker shows initiative in this sense, even if this is a small matter. Managers are often required to show initiative. However, in this case, we can still speak of self-starting, if a manager does not just follow the example of many other managers and uses “obvious” initiatives that have been suggested by several others in his area of interest but self-starts an action that is not an obvious choice.

Proactivity means to have a longterm focus and not to wait until one *must* respond to a demand. A longterm focus at work enables the individual to consider things to come (new demands, new or reoccurring problems, and emerging opportunities) *and* to do something about them now. Thus, problems and opportunities are anticipated, and the person prepares to deal with the problems and to take advantage of opportunities. An example is a secretary in a university department who books travel tickets for her boss. Her formal task is to phone the travel agency the university uses. Perhaps she or he is not satisfied with the service and finds the discount unattractive and, therefore, decides to find out whether one can get better deals somewhere else. In this case, the secretary acts in a proactive manner because she or he anticipates having to take care of travel arrangements in the future. This example also illustrates that PI can lead to changes in the environment.

Persistence is frequently necessary to reach one's goal; PI usually implies that a process, a procedure, or a task is added or modified and these changes often involve setbacks and difficulties. For example, people affected by the changes may not like having to adapt to something new and being forced to abandon their routines. This requires persistence in overcoming barriers from the person taking initiative in order to get past technical problems and to overcome other people's resistance and inertia. Sometimes, persistence also has to be shown toward supervisors who do not like their subordinates going beyond the boundaries of their jobs.

Theoretically, the three aspects of PI—self-starting, proactiveness, and persistence—reinforce each other. A proactive stance is associated with the development of self-started goals, because a proactive orientation toward the future makes it more likely to develop goals that go beyond what one is expected to do. Self-started goals are related to being persistent in overcoming barriers because of the changes inherent in their implementation. Overcoming barriers can also contribute to self-starting goals, because unusual solutions to overcome barriers often require a self-start. Finally, self-starting implies that one looks at potential future issues, and, therefore, there is a higher degree of proactivity and higher proactivity, in turn, is related to being more self-starting because one wants to exploit future opportunities that others do not yet see. Thus, there is a tendency for these three aspects of PI to co-occur (Frese et al., 1997).

In principle, PI can be directed against the longterm interests of the organization or against the longterm interests of oneself (e.g., to be self-starting in illegal substance abuse) but we conceptualized PI to be aimed at producing on average longterm positive or at least neutral outcomes for the individual and/or for the company. Research has shown that PI is positively linked to important outcomes. For example, prior individual PI has been shown to be related to obtaining a new job after becoming unemployed (Frese et al., 1997), PI is associated with entrepreneurial success in small business owners (Fay & Frese, 2001), and with performance in employees (Thompson, 2005); organizational-level PI (as organizational climate) predicts increasing profitability of firms (Baer & Frese, 2003).

The Effects of Work Characteristics on PI

We propose that two aspects of work characteristics – control and complexity at work – influence PI (cf. Figure 1). Control at work implies having an influence on sequence, time frame, and content of one's work goals, on one's work strategies, feedback, and on working conditions (Frese, 1989). Complexity has been defined by the number of elements that need to be considered (Wood, 1986) – a large number of elements implies that the work provides many options for

decision making. Control and complexity at work are often combined into one factor (e.g., Karasek & Theorell, 1990), because conceptually, both characteristics refer to decision possibilities. Control is trivial if exerted in a job with little complexity because decisions then refer to unimportant issues only. Empirical correlations between control and complexity are high (for example, in one study $r = .42$ (measured on the level of job incumbents) and $.70$ (observers' ratings), Semmer, 1982).

The notion that control and complexity are important work characteristics follows from occupational socialization theory¹ (Frese, 1982; Kohn & Schooler, 1978) and is empirically supported (Spector, 1986). Control and complexity have been shown to be related to ill-health (Karasek & Theorell, 1990), intellectual flexibility (Kohn & Schooler, 1978), and work motivation (Hackman & Oldham, 1976). They are also empirically central to the job characteristics model of Hackman and Oldham as demonstrated by their strongest relationship with the overall job motivation potential (Hackman & Oldham, 1975; Wall, Clegg, & Jackson, 1978).

High levels of work characteristics (i.e., control and complexity) should enhance PI because these increase the sense of responsibility for the whole job (Hackman & Oldham, 1976) and are associated with a broader and more proactive role orientation (Parker, Wall, & Jackson, 1997). This enhances PI by stimulating proactive thinking, self-starting approaches, and overcoming barriers. High levels of work characteristics also contribute to higher knowledge of job relevant dimensions (Holman & Wall, 2002). Knowing one's job permits seeing opportunities for PI and provides the skills to intervene. The success of autonomous work groups depends on people developing an active approach to work. Much of the job redesign performed to introduce autonomous work groups is therefore focused on increasing control and complexity (Wall et al., 2002). We similarly suggest that work characteristics affect PI; however, this relationship works via the mediator control orientation (Figure 1).

The Mediating Role of Control Orientation

We define control orientation as a belief that one is in control of relevant and important issues at work and that it pays off to have such control. This is in agreement with other self-

¹ Although there is high overlap, occupational socialization can be distinguished from organizational socialization. There are three interfaces between the organization and the individual: colleagues, managers, and work characteristics (including rules and procedures). The latter constitute the substance of occupational socialization (Frese, 1982) and managers and colleagues are the locus of organizational socialization.

regulation concepts (DeShon & Gillespie, 2005; Heckhausen & Schulz, 1995) which talk about (a) the desire to exercise control at work (control aspiration) (Rothbaum, Weisz, & Snyder, 1982); (b) the expectation to have such control (perceived opportunity for control) (Rotter, 1972); and (c) the confidence to have the ability to exercise control effectively (self-efficacy) (Bandura, 1997). Thus, control orientation is composed of control aspiration, opportunity for control, and self-efficacy. Control orientation is conceptualized to function similarly to critical psychological states (Hackman & Oldham, 1976) that also mediate between work characteristics and outcomes.

Work characteristics should have an effect on control orientation. More specifically, *control aspirations* are reduced by lack of control, as suggested by the helplessness model (Seligman, 1975). Lack of options and thwarting control leads to helplessness which produces negative motivational consequences because the organism stops trying to control the environment when it does not expect any positive outcomes (Heckhausen & Schulz, 1995; Rothbaum et al., 1982; Seligman, 1975). Abramson, Seligman, and Teasdale (1978) have shown that helplessness can be broadly generalized. The helplessness effect appears even if there are short-lived opposite effects as well, such as the reactance effect: Wortman and Brehm (1975) combined reactance and helplessness theories by showing that in the short term, lack of control and options increase aspiration for control, as reactance theory suggests. However, if attempts to increase control and options get thwarted over a long period of time, learned helplessness develops - thus, in the long run, reduced control aspirations result.

Perceived opportunity for control implies that the work environment allows people to control certain outcomes and decisions that lead to these outcomes. People tend to generalize from past experiences; if they have high control and complexity at work, they tend to predict that future relevant work characteristics will also be controllable (Abramson et al., 1978; Rotter, 1972). Thus, a construct of perceived opportunity for control in the work environment develops.

Self-efficacy – the belief of being able to perform a certain action effectively – is central for Bandura's (1997) concept of reciprocal determinism. Self-efficacy increases as a result of high control and complexity at work because they provide mastery experiences (Bandura, 1997). Mastery experiences at work exist if one controls complex tasks – if a person is in control of a noncomplex task, mastery is trivial and, therefore, no self-efficacy can develop (self-efficacy has only been measured in areas where the skill component is important; therefore, there is an inherent implication here that self-efficacy refers to mastery experiences in cognitively complex or in emotionally difficult task environments). On average, these mastery experiences at work should be positive,

because we assume that most companies do not provide a high degree of control and complexity at work to employees who are not able to produce desired results.

Control aspiration, perceived opportunity for control, and self-efficacy at work have a common core and are, therefore, related to each other empirically and theoretically - we call the common core “control orientation”. All three variables are motivational with a coherent theme that refers to expectations of being in control over relevant issues at work; this includes control aspiration because the expectation of non-control leads to a reduction of aspirations to control (Seligman, 1975). The common idea among people with high control orientation is that they are in control of relevant and important issues in their work situation and that it pays off to have such control. In contrast, people with a low control orientation believe that they cannot master the relevant parts of their work situation. This common core appears because there is some redundancy between outcome control (perceived opportunity for control) and action control (self-efficacy), and between aspiration for control and the belief that one has control. However, we do not discount that there are unique parts to each one of these three constructs. Thus, self-efficacy, perceived opportunities for control, and control aspirations can produce unique and important predictions. In this article, we concentrate, however, on the common substrate of the three aspects of control orientation.

In our model control orientation is a critical psychological state (Hackman & Oldham, 1976), which should affect PI behavior. People with high control orientation are likely to: (a) persevere when problems arise and search for opportunities to take actions to ameliorate problems (Bandura, 1997); (b) have higher hopes for success and, therefore, take a longterm perspective in goal setting and planning which leads to more proactive approaches (Heckhausen & Schulz, 1995); and (c) actively search for information (Ashford & Tsui, 1991), which leads to a better knowledge of where to show initiative. This mediator effect is in contrast to models that assume a direct effect of work characteristics (control and complexity) on active behavior (Karasek & Theorell, 1990; Spector, 1986).

Reciprocal Influence: Effects of Personal Initiative on Work Characteristics

Thus, work characteristics affect PI via the mediator control orientation. In keeping with the reciprocal model, we hypothesize, in addition, that PI increases work characteristics, that is, enhances control and complexity (cf. Figure 1). Two mechanisms are likely to be influential: First, people with high PI may generate some added complexity and control in their given jobs. The tasks of a job are not completely fixed, once and for all because of emergent elements in a job (Ilgen &

Hollenbeck, 1991) and role making can appear as a result of supervisor-member interactions (Graen & Scandura, 1987). For example, if a person develops initiatives to improve productivity, his or her work characteristics are changed and control and complexity are increased; superiors may give high PI employees more responsibilities which translates into more complex and controllable work tasks. A second mechanism involves job change. People high in PI are likely to look for and make use of opportunities for getting more challenging jobs and for increasing their career success (Seibert, Kraimer, & Crant, 2001). People with higher PI should also be more successful in finding those jobs because recruiters will more likely hire such people for challenging jobs (Frese et al., 1997), which include tasks with high control and complexity.

One of the few studies that looked at reciprocal influences between work and person characteristics was Kohn and Schooler's (1978) 10-year longitudinal study of the reciprocal effects of complexity of work and intellectual flexibility. They showed that early intellectual flexibility had a long-term effect on complexity of work and that complexity had a concurrent effect on intellectual flexibility. Our theory builds on this but takes a different focus: We are interested in the question of what *drives* the observed changes in work characteristics. Intellectual flexibility *per se* does not change work characteristics. We think that PI may be a missing link in Kohn and Schooler's model. Intellectual flexibility affects PI (Fay & Frese, 2001) and PI may change work characteristics.

Effects of Control Orientation on Work Characteristics via the Mediator PI

The reciprocal influence of PI on work characteristics discussed above also implies that PI is a mediator of the relationship between control orientation and work characteristics (cf. Figure 1). Desiring and expecting control increases PI and this, in turn, affects work characteristics to be higher (higher control and complexity). If people expect control, if they aspire for control, and if they know themselves to be competent, they influence their work characteristics to suit them better (Wrzesniewski & Dutton, 2001) and increase complexity and control at work.

METHODS

Design and Setting of the Study

In spite of frequent calls for more longitudinal studies, they are still the exceptions rather than the rule. We designed a longitudinal study consisting of six waves for the following reasons: (a) we are interested in causal effects; (b) more than three waves help reduce identification problems in structural equation modeling (Finkel, 1995); (c) they also allow the replication of the effects over time; and (d) such a longitudinal design makes it possible to test reciprocal (and, therefore, complex) models. At this time, we are not aware of any field studies on reciprocal determinism that meet these

methodological requirements. We restricted the analysis to four waves (T3 to T6) because one of the relevant PI-variables – qualitative and quantitative initiative – was first introduced at wave three.

Ideally, research on the effects of work characteristics should have a natural "zero point", for example, a given day when all participants start a new job. The study was conducted in East Germany which had such a natural "zero point" in 1990 (the starting date of East Germany's transition from socialism to capitalism was reunification with West Germany in October 1990). People experienced drastic changes at work: Nearly every company introduced new technology, new organizational structures, and often new management. Lay-offs were numerous and people had to find new jobs whereas unemployment was practically nonexistent before 1990. This situation of revolutionary job change offers us an excellent situation for examining reciprocal effects. Thus, East Germany may be a good, albeit radical, example of how global competition and technological and organizational innovations change the nature of today's jobs (Bridges, 1995). Likewise, it illustrates how – after the demise of the traditional career in Western societies – people are required to develop their career proactively (Hall, 1996).

Sample

We used a stratified random sample procedure to aim for a representative sample of the working population of Dresden (a large city in the southern part of East Germany with roughly 500,000 inhabitants). We drew a random lot to select grid squares of a map of Dresden. For each square we selected every second street that crossed the left side of these grid squares. In each street, we entered every third (apartment) house; if it was an apartment house with 6 or less parties, we talked to every third party; if it was an apartment house with more than 6 parties, we talked to each fourth party. In each party, we asked those who were between 18 and 65 and who were employed for at least 19 hours per week to participate in the study (there was practically no unemployment at T1 in socialist East Germany). Confidentiality was assured. We re-contacted the sample five times, ultimately collecting six waves of data between July 1990 and September 1995. In wave one (T1 for time 1) (July 1990), 463 people participated (a 67% response rate for the interview). This sample was representative of the Dresden population for the relevant parameters (tested against census data, e.g., for age, social class, male/female percentage at work). At wave two (T2) (November & December, 1990, right after reunification), we re-interviewed the participants of T1 and also selected 202 additional people by using the same sampling procedure as for T1. Additional people were added at T2 to ascertain whether repeated study participation had an influence on participants' responses; finding no initiative difference between the repeaters and the first-timers, we did not seek

additional research participants at subsequent waves. We call the resulting *potential* sample at T2, the “full sample” with $N=665$. Attrition of 8.9% of the participants recruited at T1, however, led to an actual sample size of 624 at T2. As previously mentioned, our analyses are based on waves three to six: At wave three (T3; September 1991), 543 individuals participated (representing a response rate of 81.6% against the “full sample”); at wave four (T4; September 1992) 506 participants responded (76.1% response rate against “full sample”), at wave five (T5; September 1993) 478 participants responded (71.9% response rate), at wave six (T6; September 1995) a total of 489 responses were received (73.5% response rate). (N was higher at T6 than at T5 because we made an extra effort to get responses from participants who had moved away from Dresden.) Experimental mortality did not change the make-up of the sample. There were no significant differences in personal initiative between those who had dropped out from T1 to T3 and those who had participated in each of the waves during this period.

As described below, it was necessary to select those who had a job into our longitudinal structural models ($n=268$). The demographic characteristics of this sample were: The mean age of participants in 1991 (T3) was 39.1 years ($SD=9.7$), 54% of the participants were male. With regard to the different levels of school education that were distinguished in East Germany, 61% graduated from school after 8 or 10 years and 37.5% obtained the highest possible school degree (which was the entry requirement for university). The remaining 1.5% left school without graduation or with an exceptional certificate. A university degree was obtained by 30.1% of all participants.

There were 31.4% of unskilled, semiskilled, and skilled blue-collar workers; 23.6% lower level white-collar workers, such as lower professionals and administrative workers; 42% higher professionals and managers. Thirty-nine percent of the sample was employed in the public sector (e.g., hospitals, education, and public administration), the remainder worked in the manufacturing industry (22.6%), building industry (7.2%), trade, hotel, and catering industry (6.0%), and other industries (finance, utility, transportation, etc). Forty percent had been employed by their organization for three years or less; 28% for three to ten years, and 31.8% for ten years or longer.

Treatment of Missing Cases

The economic changes in East Germany are conducive to studying the implications of our model. But they also produce a greater number of true missing values due to frequent periods of unemployment, sabbaticals, educational years, etc. For example, of the 471 participants who had a job at T2, 57 did not work at T3. Participants without work could not respond to the work-related items. Therefore, we based our analyses only on those participants who were always employed (or

self-employed). Our analyses were based on the four waves T3 to T6 which resulted in a sample of 268 participants. To estimate missing data of the non-work related items, the covariance matrices were estimated with the Expectation-Maximalization (EM) algorithm, using the computer program NORMS (Schafer, 1997).

Treatment of Time

In general, the timing of effects due to working conditions is an issue that is complicated and far from being resolved theoretically or empirically (Mitchell & James, 2001). To our knowledge, theory development on the timeframe in which the effects of working conditions on orientation and in turn on behaviors unfold is too small to allow the development of theory-based hypotheses. Therefore, we did not develop an *a priori* hypothesis with regard to timing of the effects of control and complexity; instead, we explored models with different time lags.

Regarding the reciprocal path of the model -- effects of PI on work characteristics -- previous research and theoretical thinking indicates that the processes need a considerable amount of time to unfold. It takes some time to change jobs and to change work characteristics. Empirically, Kohn and Schooler (1978) found a lagged selection effect with a time lag of 10 years in the U.S. In a different area, Wilk, Desmarais, and Sackett (1995) established that people in the U.S. gravitated to jobs commensurate with their ability within a five-year period. We, therefore, tested whether PI at a given time affects working conditions four years later (this is the longest possible time lag in our analysis). Even though our lag is somewhat shorter than what the cited research suggests, effects may have unfolded in a slightly shorter time period because of the high rate of change in East Germany after reunification.

Procedure

We used behavioral and structured interviews, self-report surveys, and interviewer ratings to measure the constructs in our model. The interviewers were psychology and business students in master degree programs. Fifteen to 19 interviewers were involved in each of the four waves reported here. They received two days of training in interviewing and coding. The training consisted of a standard interviewer training (e.g., how to approach participants, how to take protocols, professional issues, asking questions), and training on the different areas of the interview (e.g., on personal initiative, activities of unemployed). This included observation and discussion of role-playing scenarios performed by the trainers, role-playing interviews while being observed and coached by the trainers, and practicing protocol taking. Coding of the transcribed information was practiced using detailed descriptions of the categories of the coding system; training was concluded after

successful calibration of raters. Nine interviewers were involved in several waves; this allowed experienced interviewers to supervise newly trained interviewers, and to accompany them in their first interviews.

Structured interviews were used to measure *personal initiative*. Participants' answers were written down by the interviewers in a short form that was later typed and used as the basis for a numerical coding system applied by the interviewer and by a second coder; the second coder was drawn from the same pool of trained interviewers. The coding system was either factual (e.g., participant is unemployed or not -- a dichotomous variable), or it involved some kind of judgment (e.g., the extent to which a certain answer constitutes initiative on a five-point scale). Exemplary anchor points were provided for judgment items.

After the interview, the participants were given surveys to complete (interviewers picked them up one or two weeks later). The surveys included measures of work characteristics (control and complexity) and of control aspiration, perceived opportunity for control, and self-efficacy.

The factor structure of the scales was tested with longitudinal confirmatory factor analyses to confirm measurement equivalence and unidimensionality, first for the individual scales and then for the second-order scales. All measures were in German. The measures with information on their source, sample items, and - if applicable - validity studies are presented in Table 1. An English translation of the scales can be provided by the authors upon request.

Interview Measures of Personal Initiative

We measured PI with the structured interview and with the interviewer evaluation. We used three measures -- interviewer evaluation, qualitative and quantitative initiative at work, and situational interview (Frese et al., 1996; Frese et al., 1997). Because they are based either on behavior shown in the interview or on the interviewers' judgments, they constitute a separate source from the questionnaire responses used for the independent and control orientation variables (alphas and sample items are described in Table 1).

Qualitative and quantitative initiative. The interviewers asked four questions on activities that can represent initiative at work (i.e., whether a respondent had presented suggestions, talked to the supervisor about a work problem, attempted to determine why work problems existed, or had changed a work procedure). The interviewer probed into the nature of the activity reported to assure its self-starting and proactive nature (i.e., to make sure it is PI). Based on the protocols, the activities that qualified as PI were rated in their level of quantitative initiative and qualitative initiative. Quantitative initiative reflects the degree to which the activity required additional energy (e.g.,

working longer hours to finish an important task although nobody required it); and qualitative initiative relates to the degree to which the problem addressed and the goal or strategy used went beyond what was expected from a person in that particular job (e.g., a blue collar worker looking into a complicated production problem and suggesting a general solution to it or dealing with a problem in such a way that it would not appear again). Qualitative and quantitative initiative were both rated on a five-point scale (1= very little PI shown; 5= very high PI shown). This resulted in eight items: four qualitative initiative items based on the activities reported with regard to the four questions asked and four quantitative initiative items. The respective qualitative and quantitative initiative items that were based on the response to the same question (e.g., activities reported regarding suggestions presented) were highly related. Therefore, the two parallel items were combined into a so-called item parcel (Marsh, Hau, Balla, & Grayson, 1998). This resulted in four item parcels. Interrater agreement values at T3 were .88, .83, .85, and .91 for the four items.

Situational interview. This scale is based on the situational interview (Latham & Saari, 1984) and consists of two subscales -- overcoming barriers and active approach. *Overcoming barriers* captures a participant's initiative and persistence in overcoming obstacles. Interviewers confronted the participants with four fictional problem situations both at and outside work (e.g., unemployment compensation is reduced) and asked them what they would do. After the participant suggested a way to deal with this problem (representing the first barrier), the interviewer would then present a reason why this solution would not work out and, thus, creating a *new barrier*. This procedure continued until the third barrier was presented. Then, the respondents were asked whether they could think of additional solutions. These were written down and later counted as if they had been replies to barriers. Each solution was counted as one 'barrier overcome' if the solution was in principle feasible, was likely to have the desired effect, and did not present a small variant of a previous solution. Each barrier was counted without further weighting. We coded the number of barriers a respondent had overcome in the following way: 1 = no barrier overcome, 2 = one barrier overcome, 3 = two barriers ... 6 = five or more barriers overcome. Interrater agreement values at T3 for barriers overcome were .78, .82, .80, and .81, and for the sum of the four items, $r = .86$.

To avoid potential testing effects due to participants recalling the problem situations, we changed the problem situations across the waves. Different problems were used at T3, T4, and T5; only T3 problems were repeated at T6. The problems were as follows: (T3 and T6) your unemployment compensation is reduced; you are thrown out of your apartment; your job is terminated; you want to take some continuous education classes; T4: in your apartment something

needs to be repaired but you can't find a company to do that; you want to give advice to a friend, who is unable to find a preschool for his or her child to attend; you want to start a firm and you need a loan; you give advice to somebody who wants to open a shop but has not found a suitable location for it; T5: your machine breaks down; you are supposed to get supplies from another department but you do not get them; you make a suggestion for improving work to your supervisor but he/she does not react; a colleague always works sloppily.

The scale *active approach* captures the degree of proactivity shown by the respondent in overcoming the barriers. The raters coded the respondents' answers to each problem situation on a five-point scale as to the degree to which a respondent delegated the problem to someone else such as the supervisor (1= active) or personally strived to solve the problem (5=passive, reverse coded). Because *overcoming barriers* and *active approach* were highly correlated, the two parallel items were combined into four item parcels which were aggregated into the scale *situational interview*; the average cross-sectional intercorrelation of overcoming barriers and active approach was .52.

Interviewer evaluation. To use the interviewers as an additional source of information, we asked them to fill out a brief questionnaire about the participant ("interviewer evaluation") immediately following each interview. The interviewers evaluated the respondent's initiative with three semantic differentials scales with the following end points: 1= s/he behaves actively – 5 = s/he behaves passively; 1= s/he is goal-oriented – 5= s/he gets easily diverted from goal; 1= s/he is motivated to act – 5= s/he would rather not act (all reverse coded). Interviewers were trained to use this measure. Because the interviewers knew the participants well after interviewing them for about 70 minutes, their ratings are a valuable additional source for evaluating the participants' PI. These ratings were designed to capture the interviewers' subjective perceptions of the participant during the whole interview. Hence inter-rater reliability could not be calculated for these ratings; however, the test-retest correlations were appreciable even though there were largely different interviewers across the waves (the average of one-wave test-retest correlations was .51). The mean intercorrelations of the three PI-constructs were between .38 and .43.

Previous studies provide evidence for the convergent and discriminant validity of the interview based PI measure. It converges with a questionnaire based rating of PI provided by the life partner (Frese et al., 1997) and by fellow students (Fay & Frese, 2001); and it is different from OCB (Fay, 1998). The nomological net of PI implies that PI requires abilities and skills and is motivated by person variables and environmental factors (Fay & Frese, 2001; Frese & Fay, 2001). For example, PI is related to general mental ability and job qualification (Fay & Frese, 2001). PI is also motivated by

change orientations; individuals showing PI should be open to changes and ready to bear the uncertainty associated with them because PI implies that one brings about changes. Accordingly, PI is positively related to openness to change (Fay & Frese, 2001) and negatively to psychological conservatism, which is working against change (Fay & Frese, 2000). Stressful working conditions require change; we found work stressors to spur personal initiative (Fay & Sonnentag, 2001). The nomological net also implies that PI involves behaviors that benefit the individuals showing it and the environment they are working in. Higher levels of PI are associated with finding a job faster when becoming unemployed (Frese et al., 1997) and with students' better grades (Fay & Frese, 2001). Several studies on small-scale businesses showed that the owners' PI is related to their company's success (an overview is given in Fay & Frese, 2001) and survival (Zempel, 1999).

The three personal initiative scales interviewer evaluation, qualitative and quantitative initiative at work, and situational interview were included into a second-order construct because a second-order construct captures the essence of what defines PI behaviors (i.e., self-starting, proactive, persistence), and is methodologically well balanced as the first-order constructs were based on different methods. The data suggested this to be an acceptable approach because the first-order constructs were well correlated (cross-sectional intercorrelations on average .41) and the second-order construct model had a good fit with the data (as shown later).

Survey Measures

Unless otherwise stated, survey scales used a 5-point response format ranging from 1 (*not at all true*) to 5 (*completely true*) that has been shown to be equidistant (Rohrmann, 1978). The scale values were divided by the number of items (the scale means, SD, and alphas of the scales are presented in Table 3).

Work characteristics: Control and complexity at work. To measure control and complexity at work we used two well-validated German scales (Semmer, 1982; Zapf, 1993; also reported in Frese et al., 1996). Complexity and control can be measured by surveys well because both variables show high relationships between job incumbents' self-reports and other people's judgments (Spector, 1992). We combined control and complexity into a second-order model for theoretical reasons discussed in the introduction. We modeled work characteristics with a causal indicator model. This is in contrast to the more frequently used effect indicator model. The effect indicator model assumes that each item is an indicator of the underlying construct. Thus, a latent common construct determines the observed variables which means that a change in one issue of control, for example, control over timing of rest periods is related to an equivalent change of another issue of control, for

example, over selecting one's work methods. This effect indicator model has been criticized, for instance, by Cohen, Cohen, Teresi, Marchi, and Velez (1990) who argued that in cases such as ours, one should not develop a latent construct to determine the observed variables. An alternative is to conceive the items of the work characteristics measures control and complexity as the causes; thus, the construct is a compound of the items (Bollen & Lennox, 1991, Edwards & Bagozzi, 2000). In this case, work characteristics are composite variables plus a disturbance term (MacCallum & Browne, 1993). In such a "causal indicator model", a change in one variable is not necessarily accompanied by an equivalent change in the other ones. The latent variable is then only an abstraction of control in the sense that each specific instance of control added together leads to overall higher control at work. Therefore, the work characteristics variables were not fitted with a confirmatory factor analysis (Bollen & Lennox, 1991; MacCallum & Browne, 1993; Spector & Jex, 1998, p. 357).

However, specifying the work characteristics items as causal indicators led to identification problems in our models. A condition for identification of a model including causal indicators is that each composite variable has at least two emitting paths to other constructs, which are mutually independent (MacCallum & Browne, 1993). Thus, from each composite variable, two paths should go outward to variables and these two variables should be independent of each other. If they are interrelated the model is not identified. Because identification problems prevented us from weighting the work characteristic items individually, we used an equally weighted summation of the two variables control and complexity (cf. McDonald, 1996). This procedure helped to reduce the number of variables in the model and, thus, to keep an adequate ratio of N to the number of estimated parameters (Bentler & Chou, 1987; Jackson 2003).

Control orientation (control aspiration, perceived opportunity for control, and self-efficacy). Control orientation consists of three established measures. We used a seven-item scale to measure *control aspiration* (Frese, 1984). Previous research showed that attitudes toward job control are best assessed when including the potential negative consequences of control (e.g., "I would rather be told exactly what I have to do; then I make fewer mistakes") (Frese, 1984). For the purpose of naming and scoring all mediators in the same direction, we reversed the original scoring and called it control aspiration. Prior validity studies (Frese, Erbe-Heibokel, Grefe, Rybowskiak, & Weike, 1994) showed that this scale was related to wanting control and accepting responsibilities. People with a low degree of control aspiration also had negative attitudes toward errors, evaded complex work, did not like changes, and were bitter about changes at work. The scale *perceived opportunity for control* has

been developed in prior studies, starting with qualitative studies, several pilot studies (with up to 100 subjects), and then two cross-sectional and two longitudinal studies (Frese, 2003) and is used in Germany (e.g., by Buessing, 1999). The measure consists of six items. We assessed both perceived individual and collective opportunities for control because many facets of work (e.g., climate in the group) can only be influenced by cooperating with others. Respondents were asked to rate the level of their influence in three target areas twice, first, their influence as an individual and second, in cooperation with colleagues. The items were as follows: “As an individual, my level of influence (1) on things at my work place in general is...”; “... (2) on the climate in my department is ...”; “... (3) on decisions made by the work council is ...”. (Work councils are mandated by law in Germany). Then, the three target areas were rated again, asking for levels of influence with others: “In collaboration with my colleagues, my level of influence on ...”. We used a four-scale answer format that was pre-tested and found to produce adequate variance: very little, little, middle, rather high. In contrast to control at work, which relates directly to how one does the work itself, perceived opportunity for control asks for a more generalized appraisal of control over the work environment. It is, therefore, correlated with control at work (average of cross-sectional correlations of perceived opportunity for control with control at work = .36, cf. Table 3) and with complexity (average of cross-sectional correlations with complexity at work = .28). *Self-efficacy*. We assessed self-efficacy at work with a six-item scale (Speier & Frese, 1997). Example items are “When I am confronted with a new task, I am often afraid of not being able to handle it.” (reverse coded), “If I want to achieve something, I can overcome setbacks without giving up my goal.”. The scale correlated $r = .53$ with generalized self-efficacy (a scale developed Schwarzer, Baessler, Kwiatek, Schroeder, & Zhang, 1997), with work-related self-esteem ($r = .52$), and with optimism ($r = .38$; in all cases $p < .01$; cf. Speier & Frese, 1997). We modeled control aspiration, perceived opportunity for control, and self-efficacy as one latent variable – the appropriateness of this procedure was tested with confirmatory factor analysis (cf. next section).

Confirmatory Factor Analysis

Confirmatory factor analyses were used to test for measurement equivalence of our scales across time and for unidimensionality. Table 2 provides the fit indices of the longitudinal LISREL measurement models, tested separately for free loadings and restricting the loadings to equal factor

loadings over time.² All of the fit indices of the first-order factor models were very good, indicated by root mean square error of approximation (RMSEA) values lower than .06 and comparative fit index (CFI) values higher than .95. There were no significant differences on the chi-square tests between free and equal factor loadings for the first-order control orientation variables: perceived opportunity for control (after allowing two free loadings), self-efficacy, and control aspiration. Furthermore the Akaike information criterion (AIC) values for the more restricted and thus more parsimonious equal factor loadings models were lower. This means that the factor structure is equal across time and we can, therefore, assume measurement invariance across time. Control orientation consisted of perceived opportunity for control, self-efficacy, and control aspiration with all three showing similar loadings (standardized loadings from .43 to .66).

Measurement equivalence testing was more difficult for the three PI constructs. The situational interview asked different questions at different times (and therefore, we cannot assume complete measurement invariance) and there was only one instance of interview questions being repeated twice (the same items were used T3 and T6). As far as we used the same items, the results suggest measurement equivalence to be existent (cf. Table 2). For the non-repeated items, the factor loadings were different. For qualitative and quantitative initiative, a model with equal factor loadings yielded a lower AIC value, but the chi-square difference test was not significant at our criterion of $p < .01$. Thus, we can assume measurement equivalence as well. For the interviewer evaluation of PI, the equal loadings model had a worse fit than the free loading model (significant difference). This is not surprising given the fact that the interviewer evaluation is based on the interviewers' interpretations and that different interviewers were used at different waves. However, a partial measurement invariance found in these data in a longitudinal study is sufficient (Byrne, Shavelson, & Muthén, 1989; Pentzt & Chou, 1994).

Next, for all the first-order constructs the summated scores were calculated and used as indicators for the second-order longitudinal factor models for control orientation and personal initiative. These models fitted well with CFI values higher than .96 and RMSEA values lower than .06. Models with equal factor loadings did not fit significantly worse producing evidence for

² The first-order factor models were based on five measurement waves (T2 - T6), except for qualitative and quantitative initiative, which was added at T3 to the study and is, therefore, only available from T3 to T6. The sample sizes for the models were different (cf. Table 2), because work related measures were only collected from people who were employed at that time.

measurement invariance. Thus, for both personal initiative and control orientation the second-order models were well supported by the data.

Structural Models

Although our theoretical model is very straightforward, we had an enormously complex array of potentially analyzable models with four different measurement points, two levels of variables (first-order constructs, second-order constructs) and several different causal time lags. Therefore, we made certain decisions to reduce the number of potential models.

As pointed out earlier, we had no a priori hypotheses on the timeframe in which the effects of working conditions on control and in turn on personal initiative develop. We therefore tested different models with synchronous and lagged effects (cf. Figure 2; models I-A to I-D). In contrast, for the effect of PI on working conditions research, there is research suggesting that it takes several years to unfold (cf. Figure 2, model II-A-R). In the following, we describe the models in more detail.

The *Baseline Stability Model* assumes that there are no relationships between the variables except stabilities. It is used as a baseline model to test further structural causal models. The next models are all socialization models with substantive paths between the constructs. The *Fully Synchronous Socialization Model (I-A)* is a longitudinal model in which work characteristics have an impact on the mediating latent construct control orientation which, in turn, affects PI. It is fully synchronous because all the causal paths are assumed to work concurrently. In this model and in the following models, the previous values of the dependent variables are controlled, so that we predict residual changes (Finkel, 1995). Next, models with a mixture of lagged and synchronous effects are fitted. The first *Mixed Synchronous-Lagged Socialization Model (I-B)* tests a lagged effect from work characteristics on control orientation and a synchronous effect of control orientation on PI. The second *Mixed Lagged-Synchronous Socialization Model (I-C)* interchanges the synchronous and lagged effects. The *Fully Lagged Socialization Model (I-D)* specifies one year time lags from work characteristics on control orientation and from control orientation on PI (exception: T5-6 which represents a two-year time lag). We then tested a mediation model, called the *Socialization Plus Direct Effects of Work Characteristics Model (II-A-M1)*. It has a direct path added from work characteristics to PI and, therefore, examines whether control orientation is a full mediator in this relationship. If this model fits significantly better than the best I- model, then control orientation is not a full but at best a partial mediator.

We then tested a reciprocal model (R-model) – the *Socialization Plus Reciprocal PI-Effect Model (II-A-R)* – that tests the lagged reciprocal effect of PI on work characteristics. We

hypothesized that PI had a slow effect on work characteristics. Therefore, we calculated a model with a four-year lag (note that there was a two-year lag between T5 and T6). Finally, we tested a mediation effect by forcing the effects of work characteristics on control orientation to be zero – the *Non Socialization Model* (II-A-R-M2).

Statistical Analysis Method

All the models were tested with LISREL (version 8.54 and 8.72) using the two step approach of Anderson and Gerbing (1988) with fitting a measurement model first. Our models are complex not only because they are longitudinal, but also because they test for mediation. The use of structural equation modeling provides researchers with a good strategy to test for mediation (Brown, 1977) because it uses a simultaneous estimate of the complete model and deals with measurement error and nonrecursive parts of the model as well. Model fit was assessed by RMSEA, CFI, chi-square difference test for comparing nested models, and the AIC to compare non-nested models (Hu & Bentler, 1999). RMSEA values lower than .06 indicate good model fit, and CFI values higher than .95 are desirable (Hu & Bentler, 1999).

RESULTS

Table 3 displays the intercorrelations, means, and standard deviation of the observed variables. There was little change over time in the means for control and complexity at work (work characteristics), as well as for control aspiration, perceived opportunity for control, and self-efficacy (control orientation), whereas there was a slight decrease in PI means over time; the PI standard deviations were rather stable. Stabilities tended to be moderately high for work characteristics (one-wave stabilities were between .55 and .68, i.e., people tend to stay in the same type of job), and for perceived opportunity for control (from .55 to .59); they were higher for self-efficacy (.71 to .75), control aspiration (.67 to .75), and PI (.69 to .79). Table 3 shows that all prerequisites for mediation effects are met for all waves (Baron & Kenny, 1986). There were sizeable intercorrelations between work characteristics, the mediator variables control aspiration, perceived opportunity for control, and self-efficacy (control orientation), and PI.

Table 4 displays the fit indices for the structural models. The Maximum Model imposes (in contrast to all models depicted in Figure 2) *no constraints* on the relationships between the latent variables. It therefore fits the data very well and can be used as a best-fit comparison model. The Baseline Model does not fit very well in comparison to the Maximum Model. The fit of the Baseline Model improves clearly by allowing autoregressive paths from T3 PI to T5 and T6 PI. This may indicate that there are some state fluctuations so that not only the immediately preceding PI score is

predictive of later PI, but also the T3 PI score (Kenny & Campbell, 1989). This is not surprising in a historically volatile situation such as the one in East Germany in which T3 was the last year of some stability. The T4 score of PI could be more strongly influenced by the profound changes in comparison to later waves; hence in later waves, people showed their typical behavior pattern (as presented in T3) to a greater extent.

The Modified Baseline Stability Model's fit indices improve by specifying the hypothesized substantial paths between the constructs. All of the I (Socialization)-Models had adequate fit indices and all but one were significantly better than the Modified Baseline Model (cf. the chi-square difference tests in Table 4). Models that differ only in time lags but otherwise hypothesize identical structural relationships very rarely show substantial fit differences. Considering this, the Fully Synchronous Socialization Model (Model I-A) appears to be the best because it consistently showed the highest fit indices and, furthermore, AIC -- the best indicator for comparing non-nested models -- showed the clearest differences to the other I-models. The I-A Model is a full mediation model: Control orientation completely mediates the effects of work characteristics on PI. Therefore, a mediation test was done by specifying a model that also allows a direct path from work characteristics to PI -- the Socialization Plus Direct Effects of Work Characteristics Model (II-A-M1). This model is not significantly better than the Fully Synchronous Socialization Model (I-A), a finding which suggests the more parsimonious Fully Synchronous Socialization Model (I-A) as the better model (Bollen, 1989).

Using the I-A Model as a starting point, we tested the reciprocal model, the Socialization Plus Reciprocal PI Effect Model (II-A-R). This model had adequate absolute goodness of fit indexes, but the modification indexes indicated that there were additional lagged paths from control orientation to work characteristics.

Therefore, we added an additional model: Socialization Plus Reciprocal PI and Control Orientation Effects Model (II-A-R2, cf. Figure 3) which tests whether there were lagged paths from control orientation to work characteristics. This model had good fit indices and it was also significantly better than the I-A Fully Synchronous Socialization Model (chi-square Δ I-A and II-A-R2 = 58.51, $df=4$, $p=0.000$) and it was significantly better than the II-A-R model (chi-square Δ II-A-R and II-A-R2 = 44.04, $df=3$, $p=0.000$). Moreover, this model had an AIC fit that was even better than the Maximum Model; thus, its fit to the data is excellent. The longterm reciprocal effect of PI -- covering a span of 4 years -- was significant (all models with shorter time lags had worse fit indices --

results not shown). The effect of prior work characteristics on later work characteristics appeared because of the stability between the two waves of work characteristics but *also* because of the mediation via control orientation and the lagged effects of PI on work characteristics. To examine whether partial mediation exists, we tested the mediation effect by forcing the effects of work characteristics on control orientation to be zero – the *Non Socialization Model* (II-A-R-M2). This non-socialization model was significantly worse than the mediating model Socialization Plus Reciprocal Effects of Control Orientation (II-A-R2) (cf. Table 4), thus confirming a mediating function.

The Best Fitting Structural Model: Socialization Plus Reciprocal PI and Control Orientation Effects Model

The Socialization Plus Reciprocal PI and Control Orientation Effects Model (II-A-R2), shown in Figure 3, demonstrates that the hypothesized paths were significant and that they were regular across time. Work characteristics had significant effects on control orientation in each case (standardized path coefficients of .18 and above), as suggested by our model. Further, the effects of control orientation on PI were significant in all three cases with betas between .21 and .34. There was one long-term significant reciprocal effect of PI on work characteristics with a path of .18. This effect size was similar to the work socialization effects (the latter paths were around .22). Finally, there were additional non-expected sizeable reciprocal one-year time lagged paths from control orientation on work characteristics (.33 and above), suggesting an effect of control orientation on changes in work characteristics.

The stabilities of work characteristics between T3 and T4 were lower than the stability between T4 and T5. This coincides well with the informal observations that work place changes were most dramatic in the second year after German reunification (between T3 and T4) and then leveled off two years later. The stability between T5 and T6 was also lower than the one between T4 and T5, which is due to the time lag of 2 years (in contrast to all other time lags of 1 year).

Our results on the reciprocal PI effects on work characteristics show the hypothesized long-term effect. This is not surprising because the effects of rare behaviors such as PI do not play out quickly. Moreover, it takes some time until employees can convince peers and supervisors around them that their initiatives are worth pursuing and that they should get a higher degree of control and complexity (or that they could change to jobs with higher control and complexity). On an exploratory basis, we also modeled shorter term effects of one and two years; they were, however, not significant. This suggests a test of the whole model from a long-term perspective. We, therefore,

calculated the *Socialization Plus Reciprocal PI and Control Orientation Effects – Long-term Model* (III-A-R2-long-term, cf. Table 4) – a model with only T3 and T6 data to look at the effects as they unfold over the long term (4 years in our study). As Table 4 shows, this model had very good fit indices. Figure 4 shows that in the long term, the effect of control orientation on work characteristics (.31) became more similar to the effect of PI on work characteristics (.20) than was the case in the short term (Figure 3). Moreover, the stabilities were, of course, reduced when observing paths long term, and the substantive paths increased in size. PI had a stability of .60, control orientation of .50, and work characteristics had a relatively low stability of .24. Apparently, there was quite a lot of change in work characteristics during these four years of our study, which were to a large extent determined by control orientation and PI. The path from work characteristics to control orientation was substantial (.41), as was the path from control orientation to PI (.34).

The reciprocal effects found here imply that people with high control orientation and high initiative will eventually move to more responsible jobs with higher control and complexity or create these kinds of jobs for themselves by changing the job content. This finding speaks for reciprocal determinism in which both socialization effects *and* effects of PI and control orientation on work characteristics can be observed.

Descriptive and Qualitative Results on the Long-Term Effect of Personal Initiative

Some descriptive results and qualitative impressions may help to interpret the effects of PI on work characteristics. For this we differentiated four extreme groups (10 - 12 participants each) using data from T3 and T6: Groups showing (1) high/high or (2) low/low PI at both time periods, respectively, one group with (3) a substantial decrease (high/low), and one group with (4) a substantial increase (low/high) of PI over time. Using residualized scores of work characteristics at T6 (holding T3 work characteristics constant) illustrates the finding from the structural equation analysis that PI helped to change work characteristics. The group that had always been low in PI decreased dramatically in work characteristics over time ($M=-.55$ residualized scores), while the group that had high scores of PI both at T3 and at T6 increased in work characteristics ($M=.33$); the downward PI ($M=.13$) and the upward PI groups ($M=.10$) were in the middle ($F(3, 42)=3.75$, $p=.018$).

Examples based on the interviews with the participants further illustrate the relevance of the reciprocal model for PI. Both the group members with low PI and those with high PI at both measurement waves did not tend to change their companies. How then did the high/high PI group increase their control and complexity? It appears that this group took initiative in skill enhancement

– individuals were using and even creating learning opportunities whenever they could. For example, one supervisor of an operations planning group started learning English although it meant that he had to do that on the weekend. He did not have an immediate use for the language but thought that in the future he might need it (note: In East Germany, high school students did not learn English but Russian). In the long run, this skill enabled him to get involved in tasks of higher control/complexity. In contrast, the always-low PI group was not interested in continuing education. A security guard for the city said: “I would go to some course if I were sent.” With skills becoming outdated, loss in control/complexity in this group was a result of getting increasingly simpler tasks assigned.

The members of the downward-PI group were quite heterogeneous: Two participants had just started a new job at T3 and were at T3 quite enthusiastic; they had many ideas about changes – apparently, the reduction of PI at T6 was just an adaptation to the job. Many other members of this group used uncontrollable work demands as a reason for not having developed PI at T6 (“I do not want to participate in continuing education; I am glad if I am able to deal with my work right now”). This suggests that an increase of feelings of non-controllable overload, low self-efficacy, and low control aspirations were related to lower PI.

Similarly, the members of the upward-PI group did not fall into one simple pattern. Some had just started a new job at T6 and this may have contributed to detecting things that needed improvement from their fresh perspectives. Other participants were still in their old jobs at T6, but had received new responsibilities because of higher business volume. This piqued their PI although it had not yet translated into a noticeable increase in control/complexity. One member of this group had external reasons to show little PI at T3: This person had worked only a few hours at T3 and expected that the job would be soon eliminated. After the threat of losing the job was removed, this person increased PI at work.

This qualitative description suggests that people did not necessarily change their jobs (and even less, their company) to increase or decrease their PI; furthermore, it demonstrates that people can change the particulars of their work characteristics within a given job.

DISCUSSION

Our model has fared quite well (cf. Figures 3 and 4). First, work characteristics (control and complexity) affected control orientation (the common core of control aspiration, perceived opportunity for control, and self-efficacy); second, control orientation had a significant effect on PI;

third, there were reciprocal relationships from PI to work characteristics; and fourth, control orientation mediated the effects of work characteristics on PI.

The results seem at first glance to confirm a Marxist point of view (people are determined by work) and the notion of socialization through work. However, this notion of socialization through work needs to be refined: Work characteristics cannot directly influence behavior; instead this process is mediated by control orientation as a “critical psychological state”. The effect of work characteristics on one facet of control orientation – self-efficacy – was also found by Parker (1998).

On the other hand, the PI and control orientation effects on work characteristics seem to confirm the world view of Schopenhauer. This shows that both seemingly opposing world views by Marx *and* Schopenhauer seem to be correct. Theoretically, the two views have been integrated by Bandura’s notion of reciprocal determinism (Bandura, 1997), and our study provides an empirical underpinning for this popular, yet rarely studied, notion. Furthermore, our results are consistent with Bandura’s (1997) argument that reciprocal determinism works via self-efficacy, as self-efficacy was part of the latent factor control orientation. At the same time, the results suggest an extension of Bandura’s model. While a high level of control orientation is important for the development of work characteristics, our results suggest that PI has an additional and independent effect on control orientation.

Our study also produced unexpected findings. We had originally hypothesized that PI would fully mediate the path from control orientation to later work characteristics. This was not the case; PI is only a partial mediator as indicated by the direct lagged effects from control orientation to work characteristics. One possible interpretation is based on an effect of control orientation on delegation behavior: Supervisors delegate challenging tasks to those employees whom they have confidence in. This confidence is not just created by past performance as in past PI (Bauer & Green, 1996) but may also be shaped by the impressions the supervisor develops based on employees’ statements of control orientation. Individuals with high levels of control orientation are likely to create an impression of high reliability and competence, making them recipients of positive delegation (Bauer & Green, 1996) producing higher work characteristics.

Strengths and Limitations

Our results are based on a unique study -- a longitudinal design with four waves with various data sources. It allowed us to estimate different time lags and models with reciprocal paths without running into identification problems and to essentially replicate the findings within a single study. The longitudinal design overcomes some of the problems of common method variance or

unmeasured third variables. Because earlier levels of the variables are held constant, constant sources of common method variance (e.g., negative affectivity, response biases, personality effects) are also held constant and can be controlled to a certain extent (Zapf, Dormann, & Frese 1996). Of course, our longitudinal study could not rule out the existence of unknown and changing third variables.

Although the participants were the source of all data, an important feature of our study was our use of multiple perspectives (participants and interviewers/coders) and multiple modes of data collection to reduce percept-percept biases: survey responses, interview responses, objective performance during the interview, and interviewer evaluations. The variable overcoming barriers (which measures one part of PI) is particularly interesting because it is essentially a measure of respondents' performance during the interview (how many barriers was the participant able to overcome?). Because the coders were trained and had a common anchor point across different participants, we avoided the problem of differential anchor points that besets survey research. In the interview, we asked the participants whether they had shown certain behaviors, for example, whether they had developed an idea and implemented it. Since interviewers probed the answers, the coding procedure could isolate those behaviors that met our definition of PI (e.g., past PI behaviors). It was the coders who decided after substantial probing whether a behavior constituted PI, not the participant. Therefore, our interview may lead to type II errors of not finding PI where it exists, but it reduces type I errors of assuming PI to be present when it is not. Additionally, relatively high stabilities for PI existed even though in most cases different interviewers conducted the interviews at different time points. This indicates that our interviewer training was successful in keeping coding errors to a minimum.

One limitation of our study is that we do not have objective measures of work characteristics. Theoretical reasoning and empirical data support our assumption, however, that behavior requirements (such as complexity) can be described relatively unbiased; there is a certain kind of objectivity to the task situation (Wood, 1986). The empirical literature reports substantial correlations between job incumbents' perceptions of work characteristics and external observations (cf. Spector, 1992). Moreover, LISREL analyses hold prior perceptions of work characteristics constant. Therefore, persistent tendencies to over- or underrate work characteristics are controlled for to a certain extent. However, the possibility does exist that situational influences may have changed the perception of work characteristics at any one time. But this is not likely to be the major factor that produced the pattern of results because there was stationarity of the items across time

suggesting no change in their meaning.

Many of the paths are synchronous and synchronous paths cannot be interpreted unequivocally: They do not necessarily imply an *immediate* effect (e.g., the effects of work characteristics on control orientation). Their interpretation depends on the timeframe of the waves: If the time between two waves is one year, “synchronous” means that the effect unfolds in one year or less. As Dwyer (1983, p. 397) pointed out: “... the effects that are modeled as synchronous are actually cross-lagged effects for which the appropriate lag is much shorter than the period between waves of observation.” Thus, a conservative interpretation of our synchronous results is that the effect times are smaller than one measurement lag.

At first glance, the stabilities far outweigh the paths between the different constructs in Figure 3. Does this mean that the paths are trivial because they are so small? We argue that this is not the case. First, even small relationships have practical importance – the paths which are .28 on average (excluding stabilities) in our final model are higher than, for example, the relationship between alcohol and aggressive behavior (Meyer, Finn, Eyde, Kay, Moreland, Dies, Eisman, Kubiszyn, & Reed, 2001). Second, our design increases stabilities and decreases the correlates between variables because the model partitions the full four years into smaller pieces. Stabilities are higher if time for change is short. Therefore, the reanalysis in Figure 4 is important as it shows lower stabilities and most often higher substantive paths. If time periods are longer, stabilities may decrease and paths between the variables may increase.

Our argument that East Germany was in a situation of revolutionary job change during the course of this study might raise the question whether our findings would generalize to the more stable market economies in Western Europe and in the U.S.A. However, the relationships in our model are relatively regular across time suggesting that they would also hold (albeit maybe not as strongly and more slowly) if the change situation were not quite so radical. Evidence for this is found in the similar cross-sectional intercorrelations in East and West Germany (Frese et al., 1996). Moreover, Western economies are becoming increasingly like East Germany because of accelerating job changes in today's Western economies (Bridges, 1995).

Directions for Future Research and Practical Implications

Our results suggest future research in the area of change processes. High PI and control orientation lead to increased work characteristics. We suggest two processes to be operative: (1) changing work characteristics in current jobs by altering the boundaries of one's tasks or job and by adding or modifying elements (and maybe eliminating others; cf. the concept of job crafting,

Wrzesniewski & Dutton, 2001), and, (2) changing jobs and companies and getting jobs with higher control and complexity. Unfortunately, our study design and the situation in East Germany did not allow us to unravel these two processes, but we think it would be worthwhile to examine these processes in more detail.

Future studies should examine contingency factors. Potentially, there may also be negative effects. PI should be useful for people with high cognitive ability, knowledge, and skills. PI may also depend on job design; job design that is mechanistic, Tayloristic, and oriented toward simplification may not profit from PI and in those jobs PI may even have a negative effect on performance (Morgeson & Campion, 2002; Wall et al., 2002). In a more general sense, expectations of success and failure of PI and their effects on showing PI, as well as the factors that shape individuals' valence of showing PI will have to be empirically studied (Vroom, 1964). PI may not always be appreciated (at least in the long run) by co-workers and supervisors. People who show a high degree of PI may be perceived as being tiring and strenuous. Each initiative "rocks the boat" and makes changes. Because people tend not to like changes, they often greet initiatives with skepticism, as the literature on organizational change has shown (e.g., Begley, 1998). However, in many situations, PI should produce positive effects at work and on the way a company works (Baer & Frese, 2003).

Our results have important practical implications. Because many companies are moving from stable structures to change-oriented organizations, managers should want to increase PI so that employees support change processes effectively (Baer & Frese, 2003). Managers may have to break the vicious cycle of constrained work characteristics and lack of PI and low control orientation. Probably the best strategy is to simultaneously increase work characteristics (control and complexity) and to support the development of control orientation. Training can be used to increase control orientation by improving self-regulation (Frayne & Latham, 1987; Neck & Manz, 1996). A complementary approach is to select staff based on past PI behavior.

Our results support a pluralistic approach to encouraging initiative. There are various "entry points" or drivers to change the cycles described: work characteristics, control orientation, and PI behavior -- because all of the paths feed upon each other, the end result may be rather similar. The reciprocal model suggests, however, that organizations can produce more powerful changes if the different drivers point in the same direction. Some companies that introduce new production initiatives (e.g., quality circles or lean production) tell employees to be more daring although they keep the traditional assembly line intact and, therefore, do not increase control and complexity at work. Thus, work itself is not changed but people are encouraged to show initiative. This strategy

may be effective to a certain extent but will prove to be limited (Lawler, 1992). People who take more initiative may leave the job to find other work with more control and complexity. Others may not show any initiative because they do not have enough mastery experiences in their current jobs. Therefore, to get the strongest effect, combining several “drivers” into a general integrated approach may be best.

References

- Abramson, L. Y., Seligman, M. E. P., & Teasdale, J. D. (1978). Learned helplessness in humans: Critique and reformulations. *Journal of Abnormal Psychology, 87*, 49-74.
- Akaike, H. (1987). Factor analysis and AIC. *Psychometrika, 52*, 317-332.
- Anderson, J.C., & Gerbing, D.W. (1988). Structural equation modeling in practice: A review and recommended two step approach. *Psychological Bulletin, 103*, 411-423.
- Ashford, S. J., & Tsui, A. S. (1991). Self-regulation for managerial effectiveness: The role of active feedback seeking. *The Academy of Management Journal, 34*, 251-280.
- Baer, M., & Frese, M. (2003). Innovation is not enough: Climates for initiative and psychological safety, process innovations and firm performance. *Journal of Organizational Behavior, 24*, 45-68.
- Bandura, A. (1997). *Self-efficacy: The exercise of control*. New York: Freeman and Co.
- Baron, R. M., & Kenny, D. A. (1986). The moderator-mediator variable distinction in social psychological research: Conceptual, strategic, and statistical considerations. *Journal of Personality and Social Psychology, 51*, 1173-1182.
- Bauer, T. N., & Green, S. G. (1996). Development of leader-member exchange: A longitudinal test. *Academy of Management Journal, 39*(6), 1538-1567.
- Bentler, P.M., & Chou, C. (1987). Practical issues in structural modeling. *Sociological Methods and Research, 16*, 78-117.
- Bollen, K.A. (1989). *Structural equations with latent variables*. New York: Wiley.
- Bollen, K. & Lennox, R. (1991). Conventional wisdom on measurement: a structural equation perspective. *Psychological Bulletin, 110*, 305-314.
- Bridges, W. (1995). *Jobshift*. London: Allen & Unwin.
- Brown, R.L. (1997). Assessing specific mediational effects in complex theoretical models. *Structural Equation Modeling 4*, 142-156.
- Büssing, A. (1999). Can control at work and social support moderate psychological consequences of job insecurity? Results from a quasi-experimental study in the steel industry. *European Journal of Work and Organizational Psychology, 8*, 219-242.
- Byrne, B.M., Shavelson, R.J., & Muthén, B. (1989). Testing for the equivalence of factor covariance and mean structures: The issue of partial measurement invariance. *Psychological Bulletin, 105*, 456-466.

Cohen, P., Cohen, J., Teresi, J., Marchi, M., & Velez, C.N.(1990). Problems in the measurement of latent variables in structural equations causal models. *Applied Psychological Measurement, 14*, 183-196.

DeShon, R. D., & Gillespie, Z. J. (2005). A motivated action theory account of goal orientation. *Journal of Applied Psychology, 90*, 1096-1127.

Dwyer, J.H. (1983). *Statistical models for the social and behavioral sciences*. New York: Oxford University Press.

Edwards, J.R. & Bagozzi, R.P. (2000). On the Nature and Direction of Relationships Between Constructs and Measures, *Psychological Methods, 5*, 155-174 .

Fay, D., & Frese, M. (2000). Conservative's approach to work: Less prepared for future work demands? *Journal of Applied Social Psychology, 30, 1*, 171-195.

Fay, D., & Frese, M. (2001). The concept of personal initiative (PI): An overview of validity studies. *Human Performance, 14*, 97-124.

Fay, D. & Sonnentag, S. (2002). Rethinking the effects of stressors: A longitudinal study on personal initiative. *Journal of Occupational Health Psychology, 7*, 221-234.

Finkel, S.E. (1995). *Causal analysis with panel data*. Sage University series in Quantitative Applications in the Social Sciences (pp. 07-105). Thousand Oaks, Ca: Sage.

Frayne, C., & Latham, G. (1987). Application of social learning theory to employee self-management of attendance. *Journal of Applied Psychology, 72*, 387-392.

Frese, M. (1982). Occupational socialization and psychological development: An underemphasized research perspective in industrial psychology. *Journal of Occupational Psychology, 55*, 209-224.

Frese, M. (1984). *Do workers want control at work or don't they: Some results on denial and adjustment*. Report, Institut für Humanwissenschaft in Arbeit und Ausbildung der Technischen Universität, Berlin.

Frese, M. (2003). *Zur Konstruktvalidität von Kontrollwahrnehmung und Kontrollbewusstsein am Arbeitsplatz: Gütekriterien von Kontrollerwartung, Kontrollhoffnung, Alternativen auf dem Arbeitsmarkt und Kontrollablehnung (Construct validity of control cognitions at work: Reliability and validity of control expectancy, hope for control, alternatives on the labor market, and control rejection)*. University of Giessen: Unpublished Manuscript.

Frese, M. (1989). Theoretical models of control and health. In S.L. Sauter, J.J. Hurrell (jr.), & C.L. Cooper (Eds.), *Job control and worker health* (pp. 107-128). Chichester: Wiley.

Frese, M., Erbe-Heinbokel, M., Grefe, J., Rybowskiak, V., & Weike, A. (1994). "Mir ist es lieber, wenn ich genau gesagt bekomme, was ich tun muß" - Probleme der Akzeptanz von Verantwortung und Handlungsspielraum in Ost und West ["I prefer to be told exactly what to do" - Acceptance of responsibility and job discretion in East and West Germany]. *Zeitschrift fuer Arbeits- und Organisationspsychologie*, 38, 22-38.

Frese, M., & Fay, D. (2001). Personal initiative (PI): An active performance concept for work in the 21st century. In B.M. Staw & R.M. Sutton (Eds.), *Research in Organizational Behavior*, vol. 23 (pp. 133-187). Amsterdam: Elsevier Science.

Frese, M., Fay, D., Hilburger, T., Leng, K., & Tag, A. (1997). The concept of personal initiative: Operationalization, reliability and validity in two German samples. *Journal of Occupational and Organizational Psychology*, 70, 139-161.

Frese, M., Kring, W., Soose, A., & Zempel, J. (1996). Personal Initiative at work: Differences between East and West Germany. *Academy of Management Journal*, 39, 37-63.

Graen, G. B., & Scandura, T. A. (1987). Toward a psychology of dyadic organizing. *Research in Organizational Behavior*, 9, 175-208.

Hacker, W. (1973). *Allgemeine Arbeits-und Ingenieurpsychologie. [General work and engineering psychology]*. Berlin: VEB Deutscher Verlag der Wissenschaften.

Hackman, J. R., & Oldham, G. R. (1975). Development of the job diagnostic survey. *Journal of Applied Psychology*, 60, 259-270.

Hackman, J. R., & Oldham, G. R. (1976). Motivation through the design of work: Test of a theory. *Organizational Behavior and Human Performance*, 16, 250-279.

Hall, D. T. (1996). Protean careers of the 21st century. *Academy of Management Executive*, 10(4), 8-16.

Heckhausen, J., & Schulz, R. (1995). A life-span theory of control. *Psychological Review*, 102, 284-304.

Holman, D. J., & Wall, T. D. (2002). Work characteristics, learning-related outcomes, and strain: A test of competing direct effects, mediated, and moderated models. *Journal of Occupational Health Psychology*, 7, 283-301.

Hu, L., & Bentler, P.M. (1999). Cutoff criteria for fit indexes in covariance structure analysis: Conventional criteria versus new alternatives. *Structural Equation Modeling*, 6, 1-55.

Ilgen, D. R., & Hollenbeck, J. R. (1991). The structure of work: Job design and roles. In M. D. Dunnette & L. M. Hough (Eds.), *Handbook of industrial and organizational psychology* (pp. 165-208). Palo Alto, CA: Consulting Psychologists Press.

Jackson, D. L. (2003). Revisiting sample size and number of parameter estimates: Some support for the N:q hypothesis. *Structural Equation Modeling, 10*, 128-141.

Karasek, R. A., & Theorell, T. (1990). *Healthy work. Stress, productivity, and the reconstruction of working life*. New York: Basic Books.

Kenny, D.A., & Campbell, D.T. (1989). On the measurement of stability in over-time data. *Journal of Personality, 57*, 445-481.

Kohn, M. L., & Schooler, C. (1978). The reciprocal effects of the substantive complexity of work and intellectual flexibility: A longitudinal assessment. *American Journal of Sociology, 84*, 24-52.

Kuhl, J. (1992). A theory of self-regulation: Action vs. state orientation, self-discrimination, and some applications. *Applied Psychology: An International Review, 41*, 97-129.

Latham, G. P. (1989). Behavioral approaches to the training and learning process. In I. Goldstein (Ed.), *Training and development in work organizations: Frontiers of industrial and organizational psychology*. San Francisco: Jossey-Bass.

Latham, G. P., & Saari, L. M. (1984). Do people do what they say? Further studies on the situational interview. *Journal of Applied Psychology, 69*, 569-573.

Lawler, E. E., III (1992). *The ultimate advantage: Creating the high involvement organization*. San Francisco: Jossey-Bass.

London, M., & Mone, E. M. (1999). Continuous learning. In D. R. Ilgen & E. D. Pulakos (Eds.), *The changing nature of performance* (pp.119-153). San Francisco, CA: Jossey-Bass.

MacCallum, R.C. & Browne, M.C. (1993). The use of causal indicators in covariance structure models: Some practical issues. *Psychological Bulletin, 114*, 533-541.

Marsh, H.W., Hau, K., Balla, J.R. & Grayson, D. (1998). Is more ever too much? The number of indicators per factor in confirmatory factor analysis. *Multivariate Behavior Behavioral Research, 33*, 181-220.

McDonald, R. P. (1996). Path analysis with composite variables. *Multivariate Behavioral Research, 31*, 239-270.

- Meyer, G. J., Finn, S. E., Eyde, L. D., Kay, G. G., Moreland, K. L., Dies, R. R., Eisman, E. J., Kubiszyn, T. W., & Reed, G. M. (2001). Psychological testing and psychological assessment: A review of evidence and issues. *American Psychologist*, *56*, 128-165.
- Mitchell, T., & James, L. R. (2001). Building better theory: Time and the specification of when things happen. *Academy of Management Review*, *26*, 530-547.
- Morgeson, F. P., & Campion, M. C. (2002). Minimizing tradeoffs when redesigning work: Evidence from a longitudinal quasi-experiment. *Personnel Psychology*, *55*, 589- 612.
- Morrison, E. W. (1993). Longitudinal study of the effects of information seeking on newcomer socialization. *Journal of Applied Psychology*, *78*, 173- 183.
- Neck, C. P., & Manz, C. C. (1996). Thought self-leadership: the impact of mental strategies training on employee cognition, behavior, and affect. *Journal of Organizational Behavior*, *17*, 445-467.
- Organ, D.W. (1988). *Organizational citizenship behavior: The good soldier syndrome*. Lexington, MA: Lexington Books.
- Parker, S. K. (1998). Enhancing role breadth self-efficacy. *Journal of Applied Psychology*, *83*, 835-852.
- Parker, S. K., Wall, T. D., & Jackson, P. R. (1997). 'That's not my job': Developing flexible employee work orientations. *Academy of Management Journal*, *40*, 899-929.
- Pentzt, M.A. & Chou C.P. (1994). Measurement invariance in longitudinal research assuming change from development and intervention. *Journal of Consulting and Clinical Psychology*, *62*, 450-462.
- Pulakos, E. D., Arad, S., Donovan, M. A., & Plamondon, K. E. (2000). Adaptability in the workplace: Development of a taxonomy of adaptive performance. *Journal of Applied Psychology*, *85*, 612-624.
- Rohrman, B. (1978). Empirische Studien zur Entwicklung von Antwortskalen für die sozialwissenschaftliche Forschung [Empirical studies for the development of answer scales in social science research]. *Zeitschrift für Sozialpsychologie*, *9*, 222-245.
- Rothbaum, F. W., Weisz, J. R., & Snyder, S. S. (1982). Changing the world and changing the self: A two-process model of perceived control. *Journal of Personality and Social Psychology*, *42*, 5-37.

- Rotter, J. B. (1972). Generalized expectancies for internal versus external control of reinforcement. In J. B. Rotter, J. E. Chance & E. J. Phares (Eds.), *Applications of a social learning theory of personality* (pp. 260-294). New York: Holt.
- Schafer, J.L. (1997). *Analysis of incomplete multivariate data*. London: Chapman & Hall.
- Schopenhauer, A. (1819; 1998). *Die Welt als Wille und Vorstellung [The world as will and idea]*. Munich, Germany: Deutscher Taschenbuch Verlag.
- Schwarzer, R., Baessler, J., Kwiatek, P., Schroeder, K., & Zhang, J. X. (1997). The assessment of optimistic self-beliefs: Comparison of the German, Spanish, and Chinese versions of the General Self-Efficacy Scale. *Applied Psychology: An International Review*, 46, 69-88.
- Seibert, S. E., Kraimer, M. L., & Crant, J. M. (2001). What do proactive people do? A longitudinal model linking proactive personality and career success. *Personnel Psychology*, 54, 845-874.
- Seligman, M. (1975). *Helplessness: On depression, development and death*. San Francisco: Freeman.
- Semmer, N. (1982). Stress at work, stress in private life and psychological well-being. In W. Bachmann & I. Udrys (Eds.), *Mental load and stress in activity: European approaches* (pp. 42-55). Amsterdam: Elsevier.
- Spector, P. E. (1986). Perceived control by employees: A meta-analysis of studies concerning autonomy and participation at work. *Human Relations*, 11, 1005-1016.
- Spector, P. E. (1992). A consideration of the validity and meaning of self-report measures of job conditions. In C. L. Cooper & I. T. Robertson (Eds.), *International review of industrial and organizational psychology* (pp. 123-151). Chichester: Wiley.
- Spector, P.E., & Jex, S.M. (1998). Development of four self-report measures of job stressors and strain: Interpersonal conflicts at work scale, organizational constraints scale, quantitative workload inventory, and physical symptoms inventory. *Journal of Occupational Health Psychology*, 3, 356-367.
- Speier, C., & Frese, M. (1997). Generalized self-efficacy as a mediator and moderator between control and complexity at work and personal initiative: A longitudinal field study in East Germany. *Human Performance*, 10, 171-192.
- Staw, B. M., & Boettger, R. D. (1990). Task revision: A neglected form of work performance. *Academy of Management Journal*, 33, 534-559.

- Thompson, J. A. (2005). Proactive personality and job performance: A social capital perspective. *Journal of Applied Psychology, 90*, 1011-1017.
- Van Maanen, J. (1976). Breaking in: Socialization to work. In R. Dubin (Ed.), *Handbook of work, organization, and society* (pp. 67-130). Chicago: Rand McNally.
- Vancouver, J. B. (1997). The application of HLM to the analysis of the dynamic interaction of environment, person and behavior. *Journal of Management, 23*, 795-818.
- Vroom, V. H. (1964). *Work and motivation*. New York: John Wiley.
- Wall, T. D., Clegg, C. W., & Jackson, P. R. (1978). An evaluation of the Job Characteristics Model. *Journal of Occupational Psychology, 51*, 183-196.
- Wall, T. D., Cordery, J. L., & Clegg, C. (2002). Empowerment, performance, and operational uncertainty: A theoretical integration. *Applied Psychology: An International Review, 51*, 146-169.
- Wicklund, R. A. (1974). *Freedom and reactance*. Hillsdale: Lawrence Erlbaum.
- Wilk, S. L., Desmarais, L. B., & Sackett, P. R. (1995). Gravitation to jobs commensurate with ability: Longitudinal and cross-sectional tests. *Journal of Applied Psychology, 80*, 79-85.
- Wood, R. E. (1986). Task complexity: Definition of the construct. *Organizational Behavior and Human Decision Processes, 37*, 60-82.
- Wortman, C. B., & Brehm, J. W. (1975). Responses to uncontrollable outcomes: An integration of reactance theory and the learned helplessness model. In L. Berkowitz (Ed.), *Advances in experimental social psychology*. New York: Academic Press.
- Wrzesniewski, A. & J. E. Dutton (2001). Crafting a job: Revisioning employees as active crafters of their work. *Academy of Management Review, 26*, 179-201.
- Zapf, D. (1993). Stress-oriented job analysis of computerized office work. *The European Work and Organizational Psychologist, 3*, 85-100.
- Zapf, D., Dormann, C., & Frese, M. (1996). Longitudinal studies in organizational stress research: A review of the literature with reference to methodological issues. *Journal of Occupational Health Psychology, 1*, 145-169.

Figure 1. Theoretical Model

Figure 2. Different Structural Models.

On top, there is personal initiative, in the middle control orientation, and at the bottom work characteristics; from left to right: T3 to T6, T = time of wave.

Figure 3. Paths and Explained Variance of the Structural Equation Model of Reciprocal Socialization Plus Work Characteristics Change Model.

Ie=interviewer evaluation; Si=situational interview (overcoming barriers and active approach); Qi=qualitative and quantitative initiative at work; poc=perceived opportunity for control; s-e= self efficacy; asp= control aspiration. Autocorrelations between unique item factors not shown. All freely estimated factor loadings were significant.

Figure 4: Paths and Explained Variance of the Structural Equation Model of Socialization Plus Reciprocal Control Orientation and PI Effects Model – Long-term (includes only T3 and T6)

Ie=interviewer evaluation; Si=situational interview (overcoming barriers and active approach); Qi=qualitative and quantitative initiative at work; poc=perceived opportunity for control; s-e= self efficacy; asp= control aspiration. Autocorrelations between unique item factors not shown. All freely estimated factor loadings were significant.

Figure 1: Theoretical Model

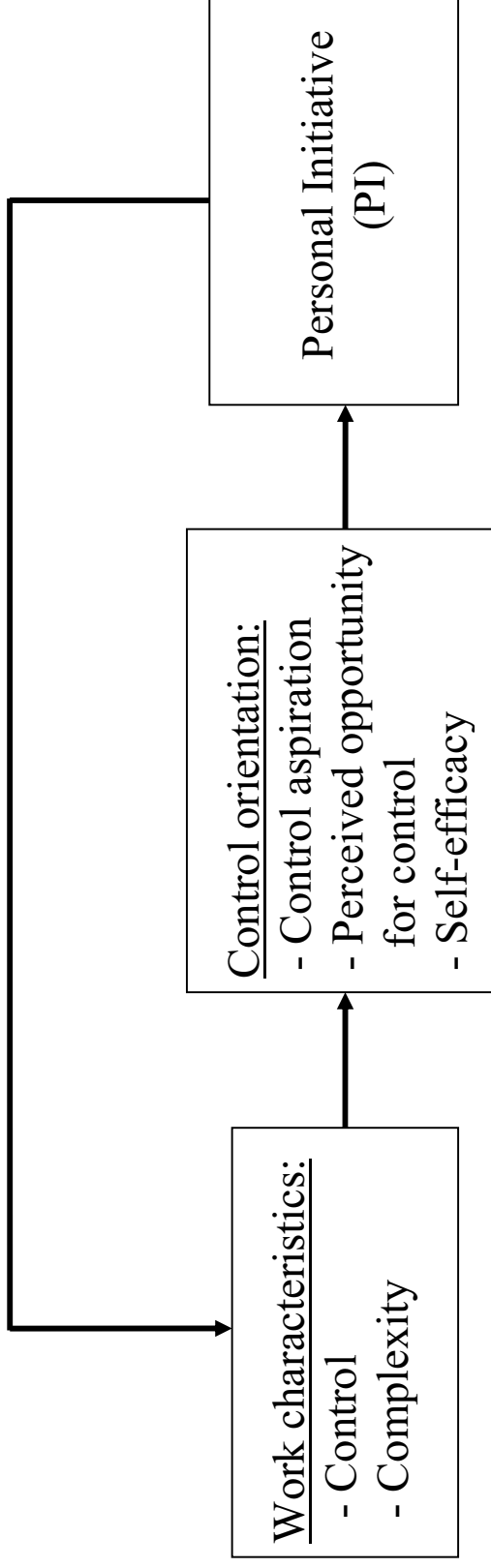

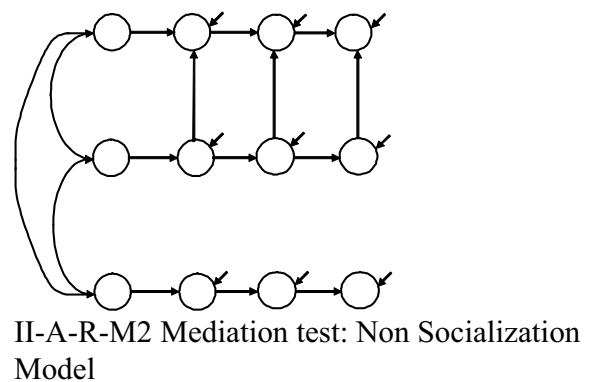
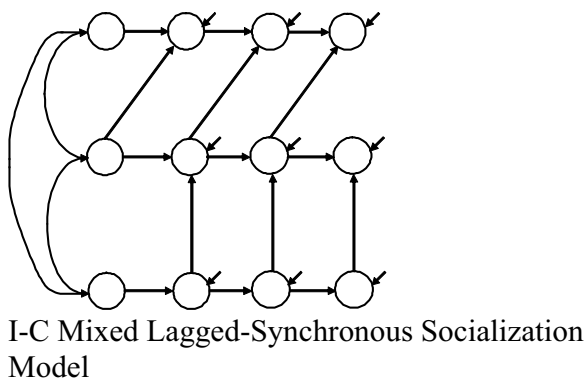
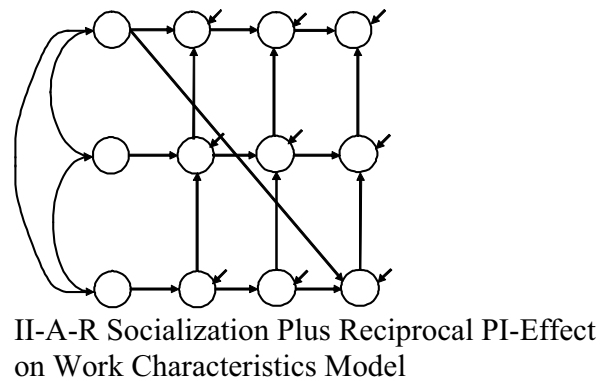
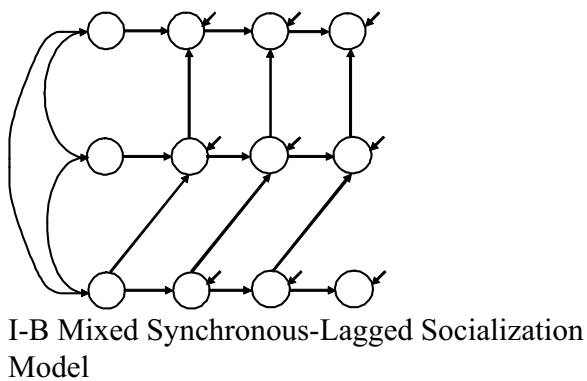
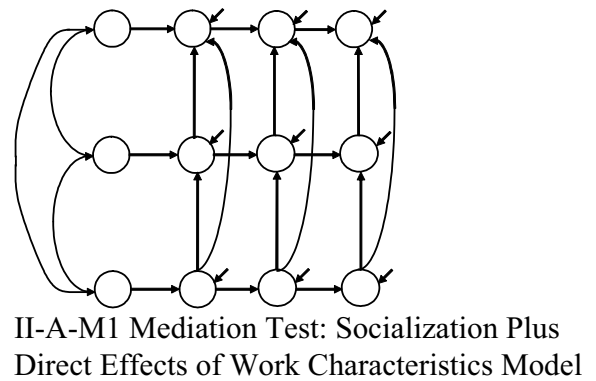
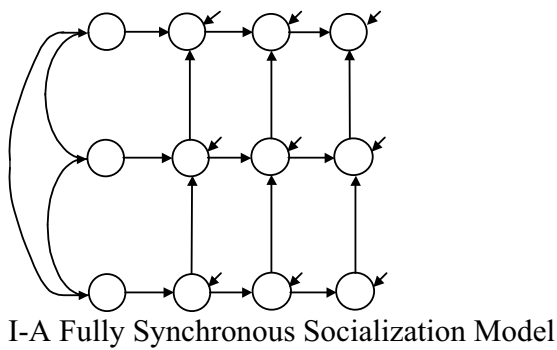
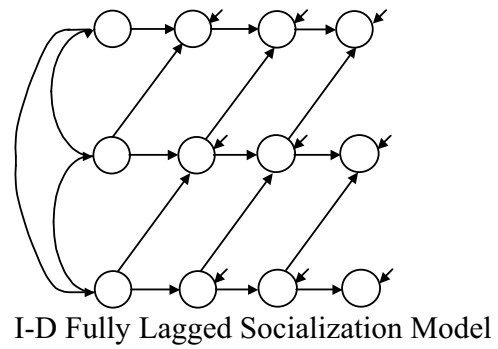
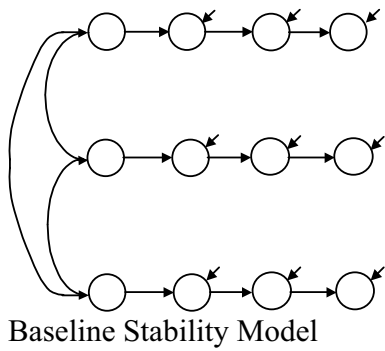

^a On top, there is personal initiative, in the middle control orientation, and at the bottom work characteristics; from left to right: T3 to T6, T = time of wave.

Figure 3

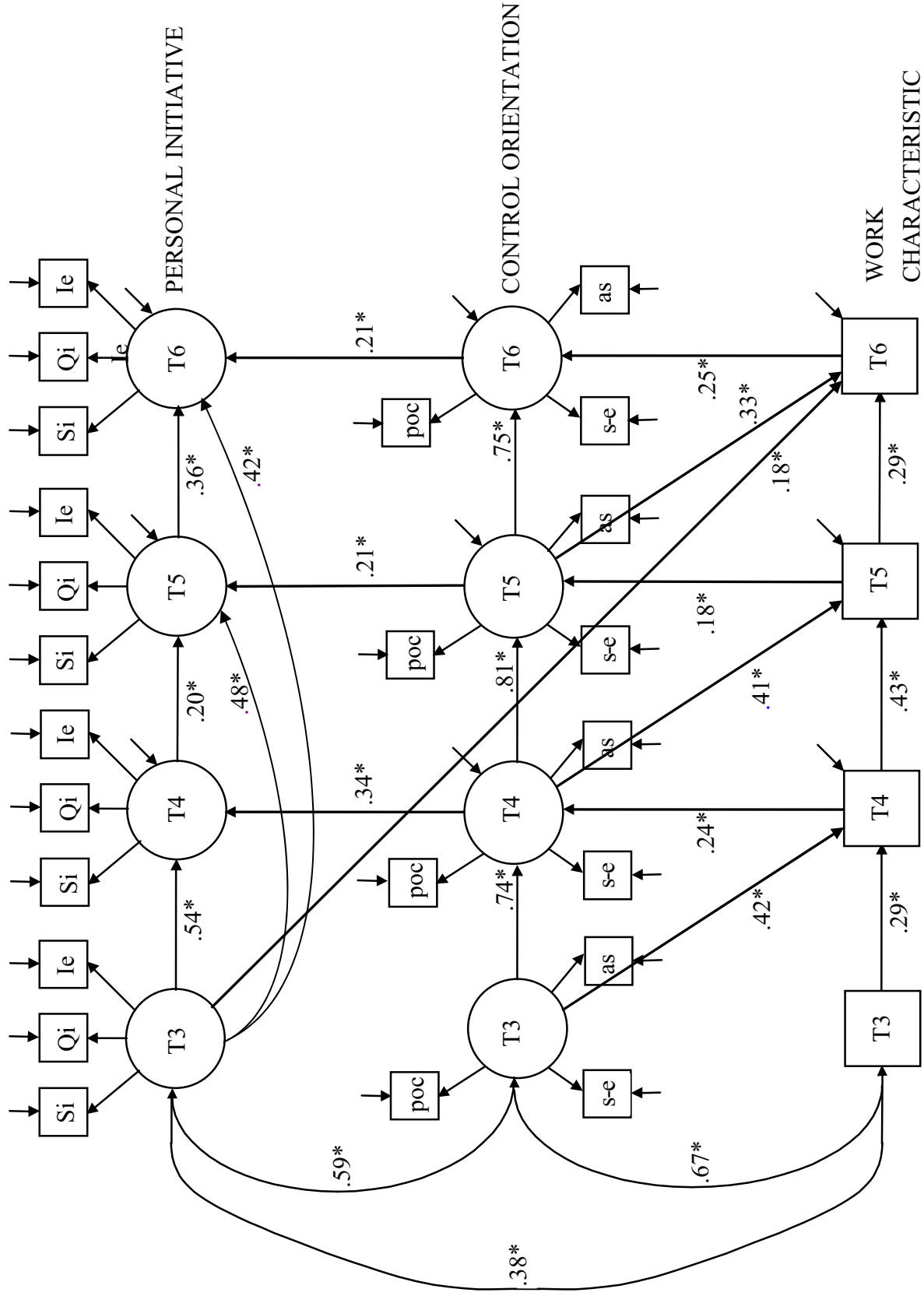

Figure 4

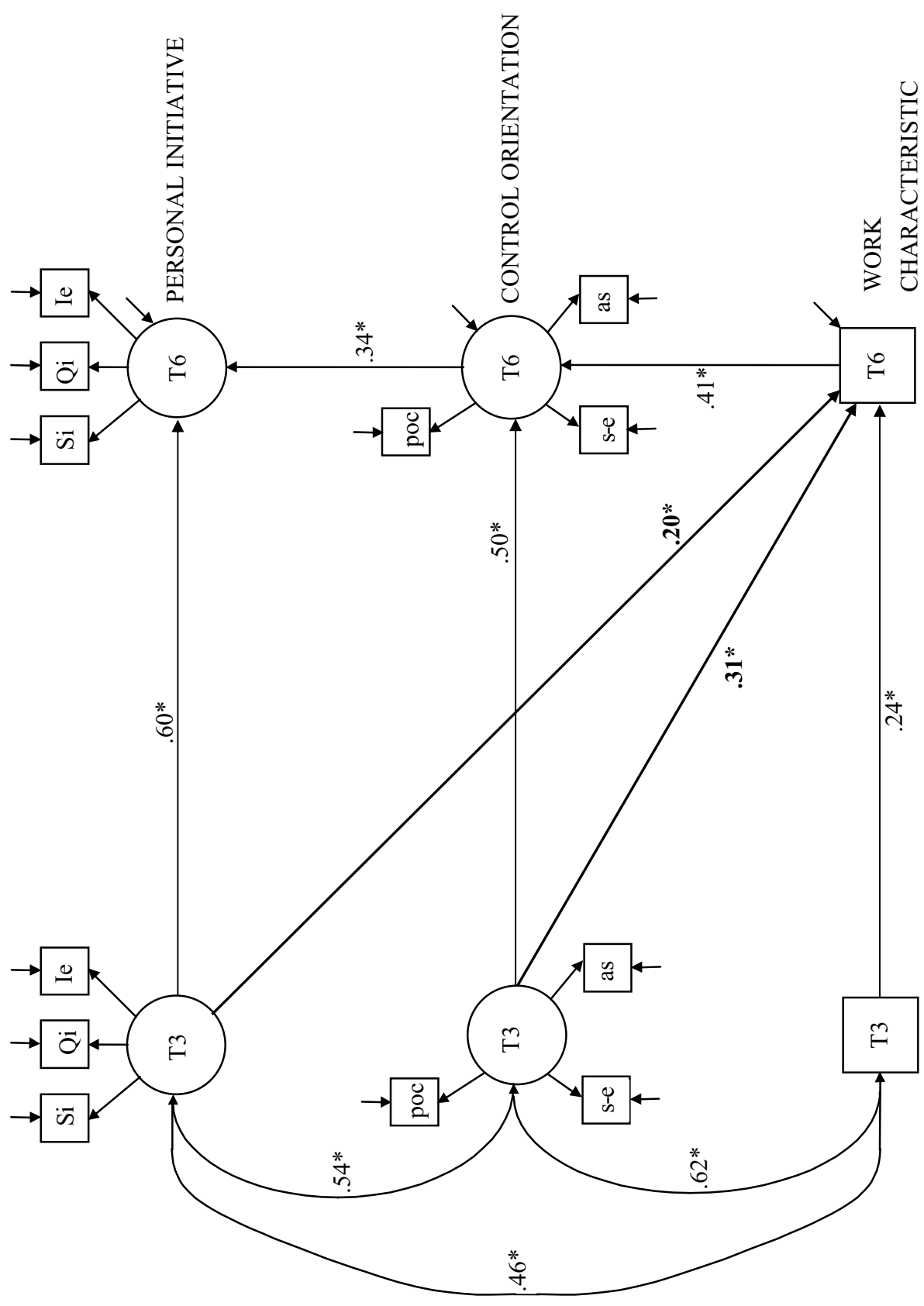

Table 1

Description of Scales and Psychometric Properties

Variable	S/I	Sample Item	Number of items: (alphas T3,4,5,6)	Source and validity studies
PI: Interviewer evaluation	I	Rating on semantic differentials based on behaviors in entire interview: "behaves actively ... passively" "goal-oriented ... easily gets diverted from goal"	3: (.88 .89; .87; .86)	Frese et al., 1996, 1997 Fay and Frese, 2001
PI: Qualitative & quantitative initiative	I	Based on reports about four areas at work (e.g., had respondent presented improvement suggestion? talked to the supervisor about a work problem?) interviewers rated degree of quantitative initiative (effort required) and qualitative initiative (degree to which goal or strategy went beyond what was expected in a particular job).	8: (.76 .78; .84; .75)	Frese et al., 1996, 1997 Fay and Frese, 2001
PI: Situational interview: Behavioral measure	I	Overcoming Barriers: Rating of persistence in dealing with four fictional problem situations (e.g., a colleague always did his or her work sloppily); Active approach: Ratings on proactivity shown in dealing with each of the problems. (The two parallel ratings were always combined into one parcel.)	4: (.77 .81 .81 .82)	Frese et al., 1996, 1997 Fay and Frese, 2001
Control at work	S	"Can you determine how you do your work?"	3: (.77 .82 .81 .83)	Frese et al., 1996; Semmer, 1982; Zapf, 1993
Complexity at work	S	"Do you receive tasks that are extraordinary and particularly difficult?"	4: (.78 .80 .73 .77)	Frese et al., 1996; Semmer, 1982; Zapf, 1993
Control aspirations	S	"I would rather be told exactly what I have to do. Then I make fewer mistakes." (reverse coded)	7: (.87 .88; .88; .90)	Frese et al., 1994
Perceived opportunity for control	S	Perceived influence on work conditions, climate, and work council decisions "Personally, my chances of influencing things at the work place are ..." "Together with others, my chances of influencing ..."	6: (.76 .75; .71; .74)	Frese, 2003
Self-efficacy	S	"I judge my abilities to be high"	6: (.72 .67 .76; .70)	Speier & Frese, 1997

A 5-point response format was used throughout. S= survey, I = Interview, PI = Personal initiative

Table 2

Goodness of Fit Measures of LISREL Longitudinal Measurement Models

	Model	χ^2	d.f.	p	RMSEA	AIC	CFI	N
<u>First-Order Longitudinal Factor Models</u>								
Perceived opportunity for Control	Factor loadings free	70.93	50	0.027	0.041	210.93	0.990	247
	Equal factor loadings	93.47	58	0.002	0.050	217.47	0.985	247
	Difference	22.54*	8	0.004				
Self-efficacy	Two factor loadings free	80.21	56	0.019	0.042	208.21	0.989	247
	Difference	9.28	6	0.158				
Control aspiration	Factor loadings free	606.43	335	0.000	0.040	866.43	0.985	519
	Equal factor loadings	628.56	355	0.000	0.039	848.56	0.985	519
	Difference	22.13	20	0.289				
Situational interview (PI)	Factor loadings free	898.71	480	0.000	0.040	1198.71	0.992	547
	Equal factor loadings	929.49	504	0.000	0.039	1181.49	0.991	547
	Difference	30.78	24	0.160				
Situational interview (PI)	Factor loadings free	258.00	160	0.000	0.034	358.00	0.981	537
	equal T2=T5 T3=T6	262.17	166	0.000	0.033	350.17	0.981	537

to be continued

Continuation of Table 2

Model	χ^2	<i>df.</i>	<i>p</i>	RMSEA	AIC	CFI	<i>n</i>
Difference	4.17	6	0.654				
Qualitative and quantitative initiative (PI)	106.35	74	0.008	0.041	230.35	0.968	263
Factor loadings free	123.25	83	0.003	0.043	229.25	0.961	263
Equal factor loadings Difference	16.90	7	0.018				
Interviewer evaluation (PI)	115.09	80	0.006	0.030	195.09	0.996	501
Factor loadings free	135.69	88	0.001	0.033	199.69	0.995	501
Equal factor loadings Difference	20.60*	8	0.008				
<u>Second-order Longitudinal Factor Models</u>							
Personal initiative (PI)	79.45	39	0.000	0.062	157.45	0.981	268
Factor loadings free	84.30	45	0.000	0.057	150.30	0.981	268
Equal factor loadings Difference	4.85	6	0.563				
Control orientation	42.08	30	0.070	0.039	138.08	0.996	268
Factor loadings free	52.80	36	0.035	0.042	136.80	0.995	268
Equal factor loadings Difference	10.72	6	0.101				

Note. * $p < .01$ (for difference χ^2 test).

Table 3
Means, Standard Deviations and Correlations

Variable	M	SD	1	2	3	4	5	6	7	8	9	10	11	12	13	14	15	16	17	18	19	20	21	22	23	24				
1. Control at work T3	3.58	.80	.77																											
2. Complexity at work T3	3.49	.70	.44	.66																										
3. POC T3	2.80	.57	.35	.25	.76																									
4. Self-efficacy T3	3.47	.51	.15	.16	.30	.72																								
5. Control aspiration T3	3.93	.64	.42	.29	.24	.30	.87																							
6. Personal initiative T3	2.85	.44	.30	.35	.28	.24	.36	-																						
7. Control at work T4	3.60	.84	.55	.23	.25	.17	.37	.22	.82																					
8. Complexity at work T4	3.50	.76	.31	.56	.20	.25	.28	.38	.43	.72																				
9. POC T4	2.83	.58	.23	.25	.55	.24	.22	.26	.29	.30	.75																			
10. Self-efficacy T4	3.51	.48	.18	.19	.27	.73	.36	.22	.30	.24	.34	.67																		
11. Control aspiration T4	3.93	.67	.36	.24	.33	.26	.67	.38	.50	.31	.30	.36	.88																	
12. Personal initiative T4	2.84	.49	.29	.31	.27	.20	.31	.72	.33	.41	.32	.28	.42	-																
13. Control at work T5	3.57	.83	.49	.29	.26	.23	.38	.38	.68	.40	.29	.30	.42	.45	.81															
14. Complexity at work T5	3.51	.70	.23	.52	.20	.16	.26	.29	.27	.66	.26	.22	.28	.30	.35	.65														
15. POC T5	2.84	.57	.29	.21	.50	.26	.25	.31	.28	.25	.59	.24	.28	.28	.42	.22	.71													
16. Self-efficacy T5	3.50	.55	.26	.25	.26	.64	.39	.30	.24	.32	.29	.75	.34	.31	.36	.26	.32	.76												
17. Control aspiration T5	3.97	.65	.34	.25	.27	.26	.68	.37	.43	.28	.30	.40	.75	.41	.47	.33	.29	.43	.88											
18. Personal initiative T5	2.39	.39	.25	.28	.31	.13	.36	.78	.28	.38	.32	.21	.44	.69	.41	.35	.33	.28	.46	-										
19. Control at work T6	3.64	.88	.45	.32	.23	.20	.37	.38	.47	.33	.24	.26	.30	.36	.60	.30	.40	.30	.38	.35	.83									
20. Complexity at work T6	3.55	.74	.22	.48	.20	.15	.28	.37	.19	.50	.21	.18	.25	.37	.25	.59	.30	.22	.29	.38	.45	.69								
21. POC T6	2.87	.57	.25	.23	.53	.31	.25	.29	.28	.27	.55	.33	.29	.29	.31	.25	.59	.34	.28	.32	.39	.34	.74							
22. Self-efficacy T6	3.53	.51	.15	.15	.20	.66	.25	.19	.24	.29	.24	.75	.25	.25	.29	.24	.21	.71	.32	.19	.29	.19	.31	.70						
23. Control aspiration T6	4.01	.70	.29	.26	.24	.21	.67	.38	.43	.39	.34	.34	.71	.38	.43	.34	.31	.36	.74	.49	.45	.37	.37	.35	.90					
24. Personal initiative T6	2.45	.44	.31	.32	.28	.18	.34	.80	.27	.42	.29	.18	.38	.67	.41	.34	.35	.31	.38	.79	.42	.41	.34	.24	.47	-				

Note: N= 286, all correlations are significant at $p < .05$, correlations above .16 are significant at $p < .01$; Cronbach's alphas in the diagonal; Personal initiative = aggregated raw score (Alphas, please consult text); POC= perceived opportunity for control

Table 4
Goodness of Fit Measures for Structural Models

Models	χ^2	<i>d.f.</i>	<i>p</i>	RMSEA	AIC	CFI
Maximum Model	443.01	310	0.000	0.040	635.01	0.984
Baseline Stability Model	681.13	364	0.000	0.057	765.13	0.962
Δ Baseline Stability Model and Maximum Model	238.12	54	0.000			
I-A	644.39	362	0.000	0.054	732.39	0.966
I-B	577.56	356	0.000	0.048	677.56	0.974
I-C	66.83	6	0.000			
I-D	625.70	357	0.000	0.053	723.70	0.968
II-A-M1	18.69	5	0.002			
II-A-R	594.01	357	0.000	0.050	692.01	0.971
II-A-R2	50.38	5	0.000			
III-A-R2-long-term	639.53	358	0.000	0.054	735.53	0.966
IV-A-R2-long-term	4.86	4	0.302			
V-A-R2-long-term	572.58	353	0.000	0.048	678.58	0.974
VI-A-R2-long-term	4.98	3	0.392			
VII-A-R2-long-term	563.09	355	0.000	0.047	665.09	0.976
VIII-A-R2-long-term	14.47	1	0.000			
IX-A-R2-long-term	519.05	352	0.000	0.042	627.05	0.982
X-A-R2-long-term	44.04	3	0.000			
XI-A-R2-long-term	58.51	4	0.000			
XII-A-R2-long-term	624.43	359	0.000	0.052	718.43	0.967
XIII-A-R2-long-term	105.38	7	0.000			
XIV-A-R2-long-term	101.73	68	0.005	0.043	175.73	0.982

Note: *N* = 268 for all models; Δ = chi-square difference test; I = Socialization models – various time lags, II = best I plus other effects, III = II-A-R2 as long-term model (T3-T6) (cf. Figure 4)